

THE CASE FOR CASE¹

Charles J. Fillmore *The Ohio State University*

¹I am grateful to the College of Arts and Sciences of the Ohio State University for releasing me from teaching duties during the winter quarter of 1967. I wish also to express my appreciation to George Lakoff (Harvard), D. Terence Langendoen (Ohio State), and Paul M. Postal (I.B.M.) for the many challenges and suggestions they have sent my way concerning the ideas of this paper. I may soon regret that I did not always follow their advice.

Speculation on language universals has not always and everywhere been viewed as a fully respectable pastime for the scientific linguist. The writer recalls a Linguistic Institute lecture of not many summers ago in which it was announced that the only really secure generalization on language that linguists are prepared to make is that 'some members of some human communities have been observed to interact by means of vocal noises'. Times have changed, it is a pleasure to report, and this is partly because we now have clearer ideas about what linguistic theories are theories of, and partly because some linguists are willing to risk the danger of being dead wrong.

Scholars who have striven to uncover syntactic features common to all of the world's languages have generally addressed themselves to three intimately related but distinguishable orders of questions: (a) What are the formal and substantive universals of syntactic structure? (b) Is there a universal base, and, if so, what are its properties? (c) Are there any universally valid constraints on the ways in which deep structure representations of sentences are given expression in the surface structure?

Concerning formal universals we find such proposals as Chomsky's, that each grammar has a base component capable of characterizing the underlying syntactic structure of just the sentences in the language at hand and containing at least a set of transformation rules whose function is to map the underlying structures provided by the base component into structures more closely identifiable with phonetic descriptions of utterances in that language (Chomsky, 1965, pp. 27-30). A representative statement on substantive syntactic universals is Lyons' assertion (1966, pp. 211, 223) that every grammar requires such categories as Noun, Predicate, and Sentence, but that other grammatical categories and features may be differently arranged in different languages. And Bach (1965) has given reasons to believe that there is a universal set of transformations which each language draws from in its own way, and he has shown what such transformations might look like in the case of relative clause modification.

Discussions on the possibility of a universal base (as distinct from claims about universal constraints on the form of the base component) have mainly been concerned with whether the elements specified in the rules of a universal base—if there is one—are sequential or not. A common assumption is that the universal base specifies the needed syntactic *relations*, but the assignment of sequential order to the constituents of base structures is language specific. Appeals for sequence-free representations of the universal deep structure have been made by Halliday (1966), Tesnière (1959), and others. Lyons (1966, p. 227) recommends leaving for empirical investigation the question of the relationship between the

underlying representation and sequential order, and Bach (1965) has suggested that continued investigation of the syntactic rules of the world's languages may eventually provide reasons for assuming specific ordering relations in the rules of a universal base.

Greenberg's (1963) statistical studies of sequence patterns in selected groups of languages do not, it seems to me, shed any direct light on the issue at hand. They may be regarded as providing data which, when accompanied by an understanding of the nature of syntactic processes in the specific languages, may eventually lend comfort to some proposal or other on either the sequential properties of the base component or the universal constraints which govern the surface ordering of syntactically organized objects.

Findings which may be interpreted as suggesting answers to our third question are found in the 'markedness' studies of Greenberg (1966) and in the so-called implicational universals of Jakobson (1958). If such studies can be interpreted as making empirical assertions about the mapping of deep structures into surface structures, they may point to universal constraints of the following form: While the grammatical feature 'dual' is made use of in one way or another in all languages, only those languages which have some overt morpheme indicating 'plural' will have overt morphemes indicating 'dual'. The theory of implicational universals does not need to be interpreted, in other words, as a set of assertions on the character of possible deep structures in human languages and the ways in which they differ from one another.

The present essay is intended as a contribution to the study of formal and substantive syntactic universals. Questions of linear ordering are left untouched, or at least unresolved, and questions of markedness are viewed as presupposing structures having properties of the kind to be developed in these pages.

My paper will plead that the grammatical notion 'case' deserves a place in the base component of the grammar of every language. In the past, research on 'case' has amounted to an examination of the variety of semantic relationships which can hold between nouns and other portions of sentences; it has been considered equivalent to the study of semantic functions of inflectional affixes on nouns or the formal dependency relations which hold between specific nominal affixes and lexical-grammatical properties of neighboring elements; or it has been reduced to a statement of the morphophonemic reflexes of a set of underlying 'syntactic relations' which themselves are conceived independently of the notion of 'case'. I shall argue that valid insights on case relationships are missed in all these studies, and that what is needed is a conception of base structure in which case relationships are primitive terms of the

theory² and in which such concepts as 'subject' and 'direct object' are missing. The latter are regarded as proper only to the surface structure of some (but possibly not all) languages.

Two assumptions are essential to the development of the argument, assumptions that are, in fact, taken for granted by workers in the generative grammar tradition. The first of these is *the centrality of syntax*. There was a time when a typical linguistic grammar was a long and detailed account of the morphological structure of various classes of words, followed by a two- or three-page appendix called 'Syntax' which offered a handful of rules of thumb on how to 'use' the words described in the preceding sections—how to combine them into sentences.

In grammars where syntax is central, the forms of words are specified with respect to syntactic concepts, not the other way around. The modern grammarian, in other words, will describe the 'comparative construction' of a given language in the most global terms possible, and will then add to that a description of the morphophonemic consequences of choosing particular adjectives or quantifiers within this construction. This is altogether different from first describing the morphology of words like *taller* and *more* and then adding random observations on how these words show up in larger constructions.³

The second assumption I wish to make explicit is *the importance of covert categories*. Many recent and not-so-recent studies have convinced us of the relevance of grammatical properties lacking obvious 'morphemic' realizations but having a reality that can be observed on the basis of selectional constraints and transformational possibilities. We are constantly finding that grammatical features found in one language show up in some form or other in other languages as well, if we have the subtlety it takes to discover covert categories. Incidentally, I find it interesting that the concept 'covert category'—a concept which is making it possible to believe that at bottom all languages are essentially alike—was introduced most convincingly in the writings of Whorf, the man whose name

² Notational difficulties make it impossible to introduce 'case' as a true primitive as long as the phrase-structure model determines the form of the base rules. My claim is, then, that a designated set of case categories is provided for every language, with more or less specific syntactic, lexical, and semantic consequences, and that the attempt to restrict the notion of 'case' to the surface structure must fail.

³ John R. Ross pointed out, during the symposium, that some syntactic processes seem to depend on (and therefore 'follow') particular lexical realizations of just such entities as the comparative forms of adjectives. Compared adjectives, in short, may be iterated, just as long as they have all been given identical surface realizations. One can say,

- i. She became friendlier and friendlier.
- ii. She became more and more friendly.

but not

- iii. * She became friendlier and more friendly.

is most directly associated with the doctrine that deep-seated structural differences between languages determine the essentially noncomparable ways in which speakers of different languages deal with reality (see Whorf, 1965, pp. 69 ff.).

One example of a 'covert' grammatical distinction is the one to which traditional grammarians have attached the labels '*affectum*' and '*effectum*', in German '*affiziertes Objekt*' and '*effiziertes Objekt*'. The distinction, which is reportedly made overt in some languages, can be seen in Sentences 1 and 2.

1. John ruined the table.
2. John built the table.

Note that in one case the object is understood as existing antecedently to John's activities, while in the other case its existence resulted from John's activities.

Having depended so far on only 'introspective evidence', we might be inclined to say that the distinction is purely a semantic one, one which the grammar of English does not force us to deal with. Our ability to give distinct interpretations to the verb-object relation in these two sentences has no connection, we might feel, with a correct description of the specifically syntactical skills of a speaker of English.

The distinction does have syntactic relevance, however. The *effectum* object, for example, does not permit interrogation of the verb with *do to*, while the *affectum* object does. Thus one might relate Sentence 1, but not Sentence 2, to the question given in 3.

3. What did John do to the table?

Furthermore, while Sentence 1 has Sentence 4 as a paraphrase, Sentence 5 is not a paraphrase of Sentence 2.

4. What John did to the table was ruin it.
5. What John did to the table was build it.⁴

To give another example, note that both of the relationships in question may be seen in Sentence 6 but that only in one of the two senses is Sentence 6 a paraphrase of Sentence 7.

6. John paints nudes.
7. What John does to nudes is paint them.

There is polysemy in the direct object of 6, true, but the difference also

⁴ This observation is due to Paul M. Postal.

lies in whether the objects John painted existed before or after he did the painting.

I am going to suggest below that there are many semantically relevant syntactic relationships involving nouns and the structures that contain them, that these relationships—like those seen in 1 and 2—are in large part covert but are nevertheless empirically discoverable, that they form a specific finite set, and that observations made about them will turn out to have considerable cross-linguistic validity. I shall refer to these as 'case' relationships.

1. Earlier Approaches to the Study of Case

Books written to introduce students to our discipline seldom fail to acquaint their readers with the 'wrong' ways of using particular case systems as universal models for language structure. Grammarians who accepted the case system of Latin or Greek as a valid framework for the linguistic expression of all human experience were very likely, we have been told, to spend a long time asking the wrong kinds of questions when they attempted to learn and describe Aleut or Thai. We have probably all enjoyed sneering, with Jespersen, at his favorite 'bad guy', Sonnenschein, who, unable to decide between Latin and Old English, allowed modern English *teach* to be described as either taking a dative and an accusative, because that was the pattern for Old English *tecan*, or as taking two accusatives, in the manner of Latin *doceo* and German *lehren* (Jespersen, 1924, p. 175).

Looking for one man's case system in another man's language is not, of course, a good example of the study of case. The approaches to the study of case that do need to be taken seriously are of several varieties. Many traditional studies have examined, in somewhat semantic terms, the various *uses* of case. More recent work has been directed toward the analysis of the case *systems* of given languages, under the assumptions suggested by the word 'system'. A great deal of research, early and late, has been devoted to an understanding of the *history* or *evolution* of case notions or of case morphemes. And lastly, the generative grammarians have for the most part viewed case markers as surface structure reflexes, introduced by rules, of various kinds of deep and surface syntactic relations.

1.1 Case Uses

The standard handbooks of Greek and Latin typically devote much of their bulk to the classification and illustration of semantically differ-

ent relationships representable by given case forms. The subheadings of these classifications are most commonly of the form 'X of Y', where 'X' is the name of a particular case and 'Y' is the name for a particular 'use' of X. The reader will recall such terms as 'dative of separation', 'dative of possession', and so on.⁵

Apart from the fact that such studies do not start out from the point of view of the centrality of syntax, the major defects of these studies were (a) that the nominative was largely ignored and (b) that classificatory criteria which ought to have been kept distinct were often confused.

The neglect of the nominative in studies of case uses probably has several sources, one being the etymological meaning ('deviation') of the Greek term for case, *ptósis*, which predisposed grammarians to limit the term only to the nonnominative cases. The most important reason for omitting the nominative in these studies, however, is the wrongly assumed clarity of the concept 'subject of the sentence'. Müller published a study of nominative and accusative case uses in Latin, in 1908, in which he devoted 170 or so pages to the accusative and somewhat less than one page to the nominative, explaining (1908, p. 1) that '*die beiden casus recti, der Nominativ und der Vokativ, sind bei dem Streite über die Kasustheorie nicht beteiligt. Im Nominativ steht das Subjekt, von dem der Satz etwas aussagt*'.

The role of the subject was so clear to Sweet that he claimed that the nominative was the only case where one could speak properly of a 'noun'. He viewed a sentence as a kind of predication on a given noun, and every nounlike element in a sentence other than the subject as a kind of derived adverb, a part of the predication.⁶

On a little reflection, however, it becomes obvious that semantic differences in the relationships between subjects and verbs are of exactly the same order and exhibit the same extent of variety as can be found for the other case. There is in principle no reason why the traditional studies of case uses fail to contain such classifications as 'nominative of personal agent', 'nominative of patient', 'nominative of beneficiary', 'nominative of affected person', and 'nominative of interested person' (or, possibly, 'ethical nominative') for such sentences as 8 to 12, respectively.

8. He hit the ball.
9. He received a blow.
10. He received a gift.
11. He loves her.
12. He has black hair.

⁵ For an extensive description of this type, see Bennett (1914).

⁶ Quoted in Jespersen (1924, p. 107).

The confusion of criteria in treatments of the uses of cases has been documented by de Groot (1956) in his study of the Latin genitive. Uses of cases are classified on syntactic grounds, as illustrated by the division of uses of the genitive according to whether the genitive noun is in construction with a noun, an adjective, or a verb; on historical grounds, as when the uses of the syncretistic Latin ablative case are divided into three classes, separative, locative, and instrumental; and on semantic grounds, in which there is a great deal of confusion between meanings that can properly be thought of as associated with the case forms of nouns, on the one hand, and meanings that properly reside in neighboring words.

De Groot's critical treatment of the traditional classification of Latin genitive case uses is particularly interesting from the point of view taken here, because in his 'simplification' of the picture he rejects as irrelevant certain phenomena which generative grammarians would insist definitely are of syntactic importance. He claims, for example, that the traditional studies confuse difference of *referents* with differences of case uses. Thus, to de Groot the traditional three senses of *statua Myronis* (the statue possessed by Myro—*genitivus possessivus*; statue sculpted by Myro—*genitivus subjectivus*; statue depicting Myro—genitive of represented subject), as well as the subjective and objective senses of *amor patriis*, are differences in practical, not in linguistic, facts. From arguments such as this he is able to combine twelve of the classical 'uses' into one, which he then labels the 'proper genitive', asserting (1956, p. 35) that 'the proper genitive denotes, and consequently can be used to refer to, any thing-to-thing relation'. He ends by reducing the thirty traditional 'uses of the genitive' to eight,⁷ of which two are rare enough to be left out of consideration, and a third, 'genitive of locality', is really limited to specific place names.

Benveniste (1962) replied to de Groot's analysis in the issue of *Lingua* that was dedicated to de Groot. There he proposes still further simplifi-

⁷ From de Groot (1956, p. 30):

- I. adjunct to a noun
 - A. proper genitive, *eloquentia hominis*
 - B. genitive of quality, *homo magnae eloquentiae*
- II. adjunct to a substantival
 - C. genitive of the set of persons, *reliqui peditum*
- III. conjunct ('complement') of a copula
 - D. genitive of the type of person, *sapientis est aperte odisse*
- IV. adjunct to a verb
 - E. genitive of purpose, *Aegyptum profiscitue cognoscende antiquitatis*
 - F. genitive of locality, *Romae consules creabantur*
- IVa. adjunct to a present participle
 - G. genitive with a present participle, *laboris fugiens*
 - V. genitive of exclamation, *mercimoni lepidi*

cations of the classification. Noting that de Groot's 'genitive of locality' applies only to proper place names, that is, that it occurs only with place names having *-o-* and *-ā-* stems, in complementary distribution with the ablative, Benveniste wisely suggests that this is something that should be catalogued as a fact about place names, not as a fact about uses of the genitive case. Benveniste's conclusions on the remaining genitive constructions is quite congenial to the generative grammarian's position. He proposes that the so-called proper genitive basically results from the process of converting a sentence into a nominal. The distinction of meaning between 'genitivus subjectivus' and 'genitivus objectivus' constructions merely reflects the difference between situations in which the genitive noun is an original subject and those where it is an original object, the genitive representing a kind of neutralization of the nominative/accusative distinction found in the underlying sentences.⁸

At least from the two mentioned studies of uses of the Latin genitive, it would appear (a) that some case uses are purely irregular, requiring as their explanation a statement of the idiosyncratic grammatical requirements of specific lexical items, and (b) that some semantic differences are accounted for independently of assigning 'meanings' to cases, either by recognizing meaning differences in 'governing' words or by noting meaning differences in different underlying sentences. The suggestion that one can find clear special meanings associated with surface cases fails to receive strong support from these studies.

1.2 Case Systems

There are reasonable objections to approaching the case system of one language from the point of view of the surface case system of another (for example, Classical Latin) by merely checking off the ways in which a given case relation in the chosen standard is given expression in the language under observation. An acceptable alternative, apparently, is the inverse of this process: one identifies case morphemes in the new language within the system of noun inflection and then relates each of these to traditional or 'standard' case notions. To take just one recent example, Redden (1966) finds five case indices in Walapai (four suffixes and zero) and identifies each of these with terms taken from the tradition

⁸ It must be said, however, that Benveniste's desentential interpretation is diachronic rather than synchronic, for he goes on to explain that it is on analogy from these basic verbal sources that new genitive relations are created. From *ludus pueri* and *risus pueri*, where the relation to *ludit* and *ridet* is fairly transparent, the pattern was extended to include *somnus pueri*, *mos pueri*, and finally *liber pueri*. The generative grammarian may be inclined to seek synchronic verbal connections—possibly through positing abstract entities never realized as verbs—for these other genitives too. (See Benveniste, 1962, p. 17.)

of case studies: *-č* is nominative, *-∅* is accusative, *-k* is allative/adessive, *-l* is illative/inessive, and *-m* is ablative/abessive. Under each of these headings the author adds information about those uses of each case form that may not be deducible from the labels themselves. Nominative, for example, occurs only once in a simple sentence—coordinate conjunction of subject nouns requires use of the *-m* suffix on all the extra nouns introduced; accusative is used with some noun tokens which would not be considered direct objects in English; allative/adessive has a partitive function; and ablative/abessive combines ablative, instrumental, and comitative functions.

In a study of this type, since what is at hand is the surface structure of the inflection system of Walapai nouns, the descriptive task is to identify the surface case forms that are distinct from each other in the language and to associate 'case functions' with each of these. What needs to be emphasized is (a) that such a study does not present directly available answers to such questions as 'How is the indirect object expressed in this language?' (for example, the system of possible case functions is not called on to provide a descriptive framework), and (b) that the functions or uses themselves are not taken as primary terms in the description (for example, the various 'functions' of the 'ablative/abessive' suffix *-m* are not interpreted as giving evidence that several distinct cases merely happen to be homophonous).⁹

One approach to the study of case systems, then, is to restrict oneself to a morphological description of nouns and to impose no constraints on the ways in which the case morphemes can be identified with their meanings or functions. This is distinct from studies of case systems which attempt to find a unified meaning for each case. An example of the latter approach is found in the now discredited 'localistic' view of the cases in Indo-European, by which dative is 'the case of rest', accusative 'the case of movement to', and genitive 'the case of movement from'.¹⁰ And recent attempts to capture single comprehensive 'meanings' of the cases have suffered from the vagueness and circularity expected of any attempt to find semantic characterizations of surface-structure phenomena.¹¹

⁹ These remarks are not intended to be critical of Redden's study. Indeed, in the absence of a universal theory of case relationships there is no theoretically justified alternative to this approach.

¹⁰ This interpretation, discussed briefly in Jespersen (1924, p. 186), appears to date back to the Byzantine grammarian Maxime Planude.

¹¹ As an illustration of this last point, take Gonda's claim (1962, p. 147) that the Vedic dative is called for whenever a noun is used to refer to the 'object in view'. The vacuity of this statement is seen in his interpretation of

vātāya kapilā vidyut (Patanjali)
'a reddish lightning signifies wind'

as 'the lightning has, so to say, *wind in view*'.

The well-known studies of Hjelmslev (1935, 1937) and Jakobson (1936) are attempts not only to uncover unified meanings of each of the cases, but also to show that these meanings themselves form a coherent system by their decomposability into distinctive oppositions. The possibility of vagueness is, of course, increased inasmuch as the number of oppositions is less than the number of cases.¹²

The difficulties in discovering a unified meaning for each of the cases in a case system have led to the alternative view that *all but one* of the cases can be given more or less specific meanings, the meaning of the residual case being left open. This residual case can either have whatever relation to the rest of the sentence is required by the meanings of the neighboring words, or it can serve any purely caselike function not pre-empted by the other cases. Bennett tells us that Goedicke explained the accusative as 'the case used for those functions not fulfilled by the other cases'. The fact that Bennett, following Whitney, ridiculed this view on the grounds that *any* case could be so described suggests that Goedicke's remark must not have been very clearly expressed.¹³ A different approach is taken by Diver (1964), who assigns the 'leftover' function not to a particular case as such, but to whatever case or cases are not required for a given realization of what he calls the 'agency system'. Briefly, and ignoring his treatment of passive sentences, Diver's analysis is this: A verb can have one, two, or three nouns (or noun phrases) associated with it, corresponding generally to the intransitive, normal transitive, and transitive indirect object sentence types, respectively. In a three-noun sentence, the nouns are nominative, dative, and accusative, the nominative being the case of the agent and the accusative the case of the patient; the dative, the 'residue' case, is capable of expressing any notion compatible with the meaning of the remainder of the sentence. The function of the dative in a three-noun sentence, in other words, is 'deduced' from the context; it is not present as one of a number of possible 'meanings' of the dative case.¹⁴ In two-noun sentences, one of the nouns is nominative and the other either dative or accusative, but typically accusative. The nominative here is the case of the agent, but this time

¹² See, in this regard, the brief critical remarks of A. H. Kuipers (1962, p. 231).

¹³ Bennett (1914, p. 195, fn. 1). I have not yet had access to the Goedicke original.

¹⁴ The following is from Diver, 1964, p. 181:

In the sentence *senatus imperium mihi dedit* 'the senate gave me supreme power', the Nominative, with the syntactic meaning of Agent, indicates the giver; the Accusative, with the syntactic meaning of Patient, indicates the gift. The question is: Does the Dative itself indicate the recipient or merely that the attached word is neither the giver nor the gift?

Diver makes the latter choice. In particular, he states that 'knowing that *mihi*, in the Dative, can be neither the Agent (the giver) nor the Patient (the gift), we deduce that it is the recipient'.

the accusative (or the dative, whichever occurs) is the residue case. In a two-noun sentence, in other words, the accusative is not limited to the meaning of patient; it can express any number of other meanings as well. And, since it no longer contrasts with dative, it can be replaced by a dative. The choice between dative and accusative in two-noun sentences, since it is not semantically relevant, is subject to random kinds of free and conditioned variation.

Carrying the argument through, the noun found in a one-noun sentence can express any meaning relationship with the verb. The noun, though most frequently nominative, may be accusative or dative, but the choice is not based on meanings associated with these cases. When the noun is nominative its 'syntactic meaning' may be that of agent, patient, or anything else.

The inadequacy of Diver's treatment is clear. In the first place, it seems unlikely that, as used in his paper, the notions agent and patient are in any sense satisfactory semantic primitives. To agree that *imperium* in *senatus imperium mihi dedit* is the patient is nothing more than to agree to say the word 'patient' on seeing an accusative form in a three-noun sentence. For many of Diver's examples, his argument would have been every bit as convincing if he had said that an unvarying function is performed by the dative, but the role of the accusative depends on such matters as the lexical meaning of the verb. Furthermore, the 'couple of dozen verbs' which appear in two-noun sentences and which exhibit some kind of semantic correlation involving the supposedly non-significant choice of accusative or dative should probably not be set aside as unimportant exceptions.

Diver's proposal may be thought of as an attempt to identify the semantic contribution of cases seen as syntagmatically identified entities, while the positing of distinctive oppositions, in the manner of Hjelmslev and Jakobson, is an attempt to see the functioning of cases from the point of view of the concept of paradigmatic contrast. The latter view has been criticized by Kuryłowicz (1960, pp. 134, 141). The apparent contrast seen in Polish and Russian between accusative and genitive (partitive) direct object, as between 13 and 14

13. *Daj nam chleb.* 'Give us the bread!'

14. *Daj nam chleba.* 'Give us some bread!'

is not a difference in the syntactic function of the object nouns relative to the verb, but is rather a difference which falls into that area of syntax that deals with the effect of the choice of article, in languages having articles, on the semantic content of the associated noun. The fact that in Russian the difference is reflected as a difference in noun inflection does

not alone determine its character as a part of the case system proper of the language.

The vertical contrast between locative and accusative nouns after locative/directional prepositions, as in 15 and 16

15. *On прыgajet na stole.* 'He jumps (up and down) on the table.'
 16. *On прыgajet na stol.* 'He jumps onto the table.'

is a difference that would be discussed in transformational grammar terms as involving a distinction between prepositional phrases which are inside and those which are outside the verb phrase constituent. That is, a locative prepositional phrase which occurs outside the constituent VP is one which indicates the place where the action described by the VP takes place. A locative prepositional phrase inside the VP is a complement to the verb. Inside a VP the difference between the locative and directional senses is entirely dependent on the associated verb; outside the VP the sense is always locative.

Kuryłowicz discussed 15 and 16 in essentially the same terms. To him the directional phrase *na stol* is 'more central' to the verb than the locative phrase *na stole*. An apparent contrast appears just in case the same verb may appear sometimes with and sometimes without a locative (or directional) complement. There is thus no genuine paradigmatic contrast in such pairs as 13–14 or 15–16.

Kuryłowicz's own approach to the study of case systems brings another order of grammatical fact into consideration: sentence relatedness. Cases, in his view, form a network of relationships mediated by such grammatical processes as the passive transformation. The distinction between nominative and accusative, for example, is a reflection in the case system of the more basic distinction between passive and active sentences. In his terms, *hostis occiditur* becomes the predicate *hostem occidit*, the primary change from *occiditur* to *occidit* bringing with it the concomitant change from *hostis* to *hostem*.

Nominalizations of sentences have the effect of relating both accusative and nominative to the genitive, for the former two are neutralized under conversion to genitive, as illustrated by the change from *plebs secedit* to *secessio plebis* (*genitivus subjectivus*) as opposed to the change from *hostem occidere* to *occisio hostis* (*genitivus objectivus*).

The relationship between nominative and accusative, then, is a reflex of diathesis; the relationship of these two to genitive is mediated through the process of constructing deverbal nouns. The remaining cases—dative, ablative, instrumental, and locative—enter the network of relationships in that, secondarily to their functions as adverbials, they each provide variants of the accusative with certain verbs. That is, there

are verbs that 'govern' the ablative (for example, *utor*), rather than the accusative for their 'direct objects'.¹⁵

1.3 Case Histories

In addition to studies of case uses and interpretations of the cases in a given language as elements of a coherent system, the literature also contains many historical studies of cases; and these, too, are of various kinds. Some workers have sought to discover the original meanings of the cases of a language or family of languages, while others have sought to trace case morphemes back to other kinds of morphemes—either syntactic function words or some kind of derivational morphemes. Still others have seen in the history of one case system a case system of a different type—with or without assumptions concerning the 'essential primitivity' of the earlier type.

A very common assumption among linguistic historians has been that case affixes are traceable back to noncase notions. The form which eventually became the Indo-European case ending representing nominative singular masculine, that is, *-s, has been interpreted as the demonstrative *so which had been converted into a suffix indicating a definite subject; and the *so in turn is believed by some to have originated as a Proto-Indo-Hittite sentence connective (Lane, 1951). The same form has also been interpreted as a derivational morpheme indicating a specific individual directly involved in an activity, contrasting with a different derivational affix *-m indicating a nonactive object or the product of an action.¹⁶ Scholars who can rest with the latter view are those who do not require of themselves the belief that 'synthetic' languages necessarily have antecedent 'analytic' stages.¹⁷

¹⁵ Kuryłowicz (1960, pp. 138–139, 144–147, 150). Also see Kuryłowicz (1964, pp. 179–181). Somewhat similar interpretations of the connections between case and diathesis are found in Heger (1966).

¹⁶ See, for example, the statement in Lehmann, 1958, p. 190.

¹⁷ The impression is sometimes given that the identification of the etymon of a case affix brings with it an account of the intellectual evolution of the speakers of the language in question. If the interpretation of *-m and *-s as derivational morphemes is correct, it does not follow that one has discovered, in the transition from the earliest function of these elements to their later clear caselike uses, any kind of 'abstraction' process or tendency to pass from 'concrete' to 'relational' modes of thought. Our methods of reconstruction should certainly make it possible to detect basic (that is, deep-structure) linguistic evolution if it is there to discover, but the etymology of surface-structure morphemes should not lead to assumptions about deep typological differences. What I mean is that the underlying case structures of Proto-Indo-European may have been just as precisely organized as those of any of the daughter languages, and that the changes that have occurred may have been entirely a matter of morpho-phonemic detail. From the preponderance of (derived) active nouns in subject position, one generation may have 'reinterpreted' the suffix as a marker of human subject and

A second kind of speculation on historical changes within case systems traces case systems of one kind back to case systems of another kind. Of particular interest here is the suggestion that the Indo-European case systems point back to an original 'ergative' system. Case typologies will be discussed in slightly greater detail below, but briefly we can characterize an 'ergative' system as one which assigns one case (the ergative) to the subject of a transitive verb and another to both the subject of an intransitive verb and the object of a transitive verb. An 'accusative' system, on the other hand, is one which assigns one case to the subject of either transitive or intransitive verbs and another (the accusative) to the object of a transitive verb. A common feature of ergative systems is that the 'genitive' form is the same as the ergative (or, put differently, that the ergative case has a 'genitive' function).

The connection of Indo-European *-s with animateness (the subject of a transitive verb is typically animate), the original identity of the nominative singular *-s with the genitive ending, and the identity of the neuter ending *-m with the masculine accusative form have led many investigators to the conclusion that our linguistic ancestors were speakers of an 'ergative' language.¹⁸ It will be suggested below that, if such a change has taken place, it is a change which involves the notion 'subject'.

1.4 Case in Current Generative Grammar

A hitherto largely unquestioned assumption about case in the writings of generative grammarians has been made explicit by Lyons (1966, p. 218): "'case" (in the languages in which the category is to be found) is not present in "deep structure" at all, but is merely the inflexional "realization" of particular syntactic relationships'. The syntactic relationships in question may in fact be relationships that are defined only in the surface structure, as when the surface subject of a sentence (destined to assume, say, a 'nominative' form) has appeared as the result of the application of the passive transformation, or when the 'genitive' marker is

a later generation may have reinterpreted it as merely a marker for the subjectival use of a particular set of words—to state the possibilities in the most simple-minded way. The change, in short, may well have been entirely in the economies of bringing to the surface underlying structural features which themselves underwent no change whatever.

¹⁸ See particularly Uhlenbeck (1901), where the *-m ending was identified as a subject marker and the *-s as the agent marker in passive sentences (a common interpretation of 'ergative' systems), and Vaillant (1936). Lehmann (1958, p. 190) finds the arguments unconvincing, noting for example that evidence of an 'ergative' ending cannot be found in plural nouns or in \bar{a} stem feminines.

introduced as an accompaniment to a nominalization transformation. One of Chomsky's few remarks on case occurs in a discussion of the peripheral nature of stylistic inversions; although case forms are assigned to English pronouns relatively late in the grammar, determined largely by surface-structure position, the stylistic inversion rules are later still. In this way it becomes possible to account for such forms as *him I like*; the shift of *him* to the front of the sentence must follow the assignment of case forms to the pronouns (see Chomsky, 1965, pp. 221 f.).

It seems to me that the discussion of case could be seen in a somewhat better perspective if the assignment of case forms were viewed as exactly analogous to the rules for assigning prepositions in English, or postpositions in Japanese.¹⁹ There are languages which use case forms quite extensively, and the assumption that the case forms of nouns can be assigned in straightforward ways on the basis of simply defined syntactic relations seems to be based too much on the situation with English pronouns.

Prepositions in English—or the absence of a preposition before a noun phrase, which may be treated as corresponding to a zero or unmarked case affix—are selected on the basis of several types of structural features, and in ways that are exactly analogous to those which determine particular case forms in a language like Latin: identity as (surface) subject or object, occurrence after particular verbs, occurrence in construction with particular nouns, occurrence in particular constructions, and so on. The only difficulties in thinking of these two processes as analogous are that even the most elaborate case languages may also have combinations of, say, prepositions with case forms, and that some prepositions have independent semantic content. The first of these difficulties disappears if, after accepting the fact that the conditions for choosing prepositions are basically of the same type as those for choosing case forms, we merely agree that the determining conditions may simultaneously determine a preposition *and* a case form. The second difficulty means merely that a correct account will allow certain options in the choice of prepositions in some contexts, and that these choices have semantic consequences. Analogous devices are provided by the 'true' case languages, too, for example by having alternative case choices in otherwise identical constructions, or by having semantically functioning prepositions or postpositions.

The syntactic relations that are involved in the selection of case

¹⁹ The suggestion is of course not novel. According to Hjelmslev, the first scholar to show a connection between prepositions and cases was A.-F. Bernhardt, in *Anfangsgrunde der Sprachwissenschaft* (Berlin, 1805); see Hjelmslev, 1935, p. 24.

forms (prepositions, affixes, and so forth) are, in practice, of two types, and we may call these 'pure' or 'configurational' relations, on the one hand, and 'labeled' or 'mediated' relations on the other hand.²⁰ 'Pure' relations are relations between grammatical constituents expressible in terms of (immediate) domination. Thus, the notion 'subject' can be identified as the relation between an NP and an immediately dominating S, while the notion 'direct object' can be equated with the relation that holds between an NP and an immediately dominating VP. Where the relation 'subject of' is understood to hold between elements of the deep structure, one speaks of the deep-structure subject; where it is understood to hold between elements of the (prestylistic) surface structure, one speaks of the surface-structure subject. This distinction appears to correspond to the traditional one between 'logical subject' and 'grammatical subject'.

By 'labeled' relation I mean the relation of an NP to a sentence, or to a VP, which is mediated by a pseudocategory label such as Manner, Extent, Location, Agent.

It is clear that if all transformations which create surface subjects have the effect of attaching an NP directly to an S, under conditions which guarantee that no other NP is also directly subjoined to the same S, and if it always turns out that only one NP is subjoined to a VP in the prestylistic surface structure, then these two 'pure' relations are exactly what determine the most typical occurrences of the case categories 'nominative' and 'accusative' in languages of a certain type. For remaining case forms, the determination is either on the basis of idiosyncratic properties of specific governing words, or on the basis of a 'labeled' relation, as when the choice of *by* is determined by reference to the dominating category Extent in the extent phrase of sentences like 17.

²⁰ The distinction would be more accurately represented by the opposition 'relations' versus 'categories', because when a phrase-structure rule introduces a symbol like Manner or Extent—symbols which dominate manner adverbials and extent phrases—these symbols function, as far as the rest of the grammar is concerned, in exactly the same ways as such 'intentional' category symbols as S or NP. This fact has much more to do with the requirements of the phrase-structure model than with the 'categorial' character of the grammatical concepts involved. In an earlier paper I discussed the impossibility of capturing, in a base component of a grammar of the type presented in Chomsky (1965), both such information that *in a clumsy way* is a manner adverbial (and as such represents an instance of highly constrained lexical selection as well as a quite specific positional and co-occurrence potential which it shares with other manner adverbials) and that it is a prepositional phrase. See Fillmore (1966a).

The *intention* on the part of grammarians who have introduced such terms as Loc, Temp, Extent, and the like into their rules is to let these terms represent relations between the phrases they dominate and some other element of the sentence (that is, the VP as a whole); nobody, as far as I can tell, has actually wished these terms to be considered as representing distinct types of grammatical categories on the order of NP or preposition phrase.

17. He missed the target by two miles.

In my earlier paper (Fillmore, 1966) I pointed out that no semantically constant value is associated with the notion 'subject of' (unless it is possible to make sense of the expression 'the thing being talked about', and, if that can be done, to determine whether such a concept has any connection with the relation 'subject'), and that no semantically relevant relations reside in the surface subject relation which are not somewhere also expressible by 'labeled' relations. The conclusion I have drawn from this is that all semantically relevant syntactic relations between NP's and the structures which contain them must be of the 'labeled' type. The consequences of this decision include (a) the elimination of the category VP, and (b) the addition to some grammars of a rule, or system of rules, for creating 'subjects'. The relation 'subject', in other words, is now seen as exclusively a surface-structure phenomenon.

2. Some Preliminary Conclusions

I have suggested that there are reasons for questioning the deep-structure validity of the traditional division between subject and predicate, a division which is assumed by some to underlie the basic form of all sentences in all languages. The position I take seems to be in agreement with that of Tesnière (1959, pp. 103–105) who holds that the subject/predicate division is an importation into linguistic theory from formal logic of a concept which is not supported by the facts of language and, furthermore, that the division actually obscures the many structural parallels between 'subjects' and 'objects'. The kinds of observations that some scholars have made about surface differences between 'predicative' and 'determinative syntagms'²¹ may be accepted without in any way believing that the subject/predicate division plays a part in the *deep-structure* syntactic relations among the constituents of sentences.

Once we have interpreted 'subject' as an aspect of the surface structure, claims about 'subjectless' sentences in languages which have superficial subjects in some sentences, or reports about languages which appear to lack entirely entities corresponding to the 'subjects' of our grammatical tradition, no longer need to be regarded as particularly disturbing. Unfortunately, there are both good and bad reasons for asserting that par-

²¹ See, for example, Bazell (1949, esp. p. 8), where the difference is expressed in such terms as 'degrees of cohesion', 'liaison features' found within the predicate but not between subject and predicate.

ticular languages or particular sentences are 'subjectless', and it may be necessary to make clear just what I am claiming. A distinction must be drawn between *not having* a constituent which could properly be called 'subject', on the one hand, and *losing* such a constituent by anaphoric deletion, on the other hand.²² Robins (1961), in his review of Tesnière (1959), accuses Tesnière of failing to isolate the subject from the rest of the sentence. To Robins, Tesnière's decision to allow the subject to be treated as merely a complement to the verb must be related to the fact that the subject is omissible in such languages as Latin. If it is true that the *omissibility* of subjects is what convinced Tesnière that they are subordinated to verbs, and if the nonomissibility in any language of the subject constituent would have persuaded him that there *is* a special status for 'subject' vis-à-vis 'predicate' in the underlying structure of sentences in all languages, then that, it seems to me, is a bad reason for coming up with what might be a correct analysis.

It seems best to have a place in linguistic theory for the operation of anaphoric processes, processes which have the effect of shortening, simplifying, de-stressing sentences which are partly identical to their neighbors (or which are partly 'understood'). It happens that English anaphoric processes make use of pronominalization, stress reduction, and also deletion, under conditions where other languages might get along exclusively with deletion.²³ Under some conditions, in languages of the latter type, the deleted element happens to be the 'subject'. The non-occurrence of subject nouns in some utterances in some languages is *not* by itself, in other words, a good argument against the universality of the subject/predicate division. There are better ones. Some of these have already been suggested, others are to appear shortly.

²² The tagmemicists in particular, because of their notation for 'optional' constituents, have had to come to grips with this distinction. A 'tagmemic formula' may be thought of as an attempt to present in a single statement a quasi-generative rule for producing a set of related sentences *and* the surface structure (short of free variation in word order) of these sentences. If the formulas for transitive and intransitive clauses are expressed as i and ii respectively:

- i. \pm Subj + Pred \pm Obj \pm Loc \pm Time
- ii. \pm Subj + Pred \pm Loc \pm Time

it is clear (a) that any clause containing just a Pred can satisfy either of these formulas, and (b) that the potential appearance of such constituents as Loc and Time is less relevant to the description of these clauses than is that of the constituent Obj. Pike draws a distinction, which cross-cuts the optional/obligatory distinction, between 'diagnostic' and 'nondiagnostic' elements of clauses; see, for example, Pike (1966, esp. Chapter 1, Clauses). Grimes, on the other hand, seems to suggest introducing the 'diagnostic' constituents obligatorily, allowing for their deletion under certain contextual or anaphoric conditions. See Grimes (1964, esp. p. 16 f.).

²³ For an extremely informative description of these processes in English, see Gleitman (1965) and Harris (1957, esp. Section 16).

By distinguishing between surface- and deep-structure case relationships, by interpreting the 'subject' and 'object' as aspects of the surface structure, and by viewing the specific phonetic shapes of nouns in actual utterances as determinable by many factors that are vastly variable in space and time, we have eliminated reasons for being surprised at the noncomparability of (surface) case systems. We find it partly possible to agree with Bennett when, after surveying a few representative nineteenth century case theories, he stated (1914, p. 3) that they erred in sharing the 'doubtful assumption . . . that all the cases must belong to a single scheme, as though parts of some consistent institution'. We need not follow him, however, in concluding that the only valid type of research into the cases is an inquiry into the earliest value of each case.

Greenberg has remarked that cases themselves cannot be compared across languages—two case systems may have different numbers of cases, the names of the cases may conceal functional differences—but that *case uses* may be expected to be comparable. He predicts, for instance, that the uses of cases will be 'substantially similar in frequency but differently combined in different languages' (1966, p. 98; see also p. 80). Greenberg's recommendations on the cross-linguistic study of case uses were presented in connection with the 'true' case languages, but it seems clear that if a 'dative of personal agent' in one language can be identified with an 'ablative of personal agent' in another language, then the 'personal agent' relationship between a noun and a verb ought also to be recognizable in the so-called caseless languages on exactly the same grounds. If, furthermore, it turns out that other grammatical facts can be associated with sentences containing the personal agent relationship, it would appear that the concepts underlying the study of case uses may have a greater linguistic significance than those involved in the description of surface case systems. These additional facts might include the identification of a limited set of nouns and a limited set of verbs capable of entering into this relationship, and whatever additional generalizations prove to be stable in terms of this classification. Higher level dependencies may be discovered, such as the limitation of benefactive phrases to sentences containing a personal agent relationship in their deep structure.

The question should now be asked, of course, whether we are justified in using the term *case* for the kind of remote syntactic-semantic relations that are at issue. There is among many scholars a strong feeling that the term should be used only where clear case morphemes are discoverable in the inflection of nouns. To Jespersen, it is wrong to speak of 'analytic' cases, even when there is no 'local' meaning in the preposition phrases, because cases are one thing and preposition-plus-object constructions are another (1924, p. 186). Jespersen's position is colored a little by his belief

that the caselessness of English represents a state of progress for which we ought to be grateful.²⁴

Cassidy, in his 1937 appeal to rescue the word *case* from abuse, wrote (p. 244): "Case" will be properly used and will continue to have some meaning only if the association with inflection be fully recognized, and if stretching of the term to include other sorts of "formal" distinction be abandoned.' In a similar vein, Lehmann (1958) chides Hirt for suggesting that an awareness of cases had to precede the development of case endings—that there was, in other words, 'among the speakers of pre-Indo-European and Proto-Indo-European a disposition for cases' (p. 185). Lehmann continues (p. 185): 'We can account for Hirt's statement by the assumption that to him a case was a notional category, whether or not it was exemplified in a form. To us a particular case is non-existent unless it is represented by forms which contrast in a system with others.' The claim that syntactic relations of various types must exist before case endings could be introduced to give them expression would surely have gone unchallenged; what was offensive, apparently, was the use of the word *case*.

It seems to me that if there are recognizable intrasentence relationships of the types discussed in studies of case systems (whether they are reflected in case affixes or not), that if these same relationships can be shown to be comparable across languages, and that if there is some predictive or explanatory use to which assumptions concerning the universality of these relations can be put, then surely there can be no meaningful objection to using the word *case*, in a clearly understood deep-structure sense, to identify these relationships. The dispute on the term *case* loses its force in a linguistics which accepts the centrality of syntax.²⁵

²⁴ Jespersen (1924, p. 179):

However far back we go, we nowhere find a case with only one well-defined function: in every language every case served different purposes, and the boundaries between these are far from being clear-cut. This, in connection with irregularities and inconsistencies in the formal elements characterizing the cases, serves to explain the numerous coalescences we witness in linguistic history ("syncretism") and the chaotic rules which even thus are to a great extent historically inexplicable. *If the English language has gone farther than the others in simplifying these rules, we should be devoutly grateful and not go out of our way to force it back into the disorder and complexity of centuries ago.* [Italics added.]

²⁵ The universality of case as a grammatical category is affirmed in Hjelmslev (1935, p. 1). In a recent study from a Jakobsonian point of view, Velten (1962) reveals enough of the historical continuity of 'synthetic' and 'analytic' cases to suggest that the linguist has no right to assign cases and prepositions to different 'chapters' of the study of grammar. The deep-structure notion of cases may be thought of as involving an extension of the synchronic concept of 'syncretism'. The usual synchronic sense of case syncretism assumes the form of a decision to posit a case contrast that may not be expressed overtly in most contexts as long as it appears overtly in 'one part of the system'. (See Newmark, 1962, p. 313.) Deep-structure cases may simply be

We may agree, then, for our present purposes, with Hjelmslev, who suggests that the study of cases can be pursued most fruitfully if we abandon the assumption that an essential characteristic of the grammatical category of case is *expression in the form of affixes on substantives*. I shall adopt the usage first proposed, as far as I can tell, by Blake (1930), of using the term *case* to identify the underlying syntactic-semantic relationship, and the term *case form* to mean the expression of a case relationship in a particular language—whether through affixation, suppletion, use of clitic particles, or constraints on word order.

3. Case Grammar

The substantive modification to the theory of transformational grammar which I wish to propose amounts to a reintroduction of the 'conceptual framework' interpretation of case systems, but this time with a clear understanding of the difference between deep and surface structure. The sentence in its basic structure consists of a verb and one or more noun phrases, each associated with the verb in a particular case relationship. The 'explanatory' use of this framework resides in the necessary claim that, although there can be compound instances of a single case (through noun phrase conjunction), each case relationship occurs only once in a simple sentence.²⁶

It is important to realize that the explanatory value of a universal system of deep-structure cases is of a syntactic and not (merely) a morphological nature. The various permitted arrays of distinct cases occurring in simple sentences express a notion of 'sentence type' that may be expected to have universal validity, independently of such superficial differences as subject selection. The arrays of cases defining the sentence types of a language have the effect of imposing a classification of the verbs in the language (according to the sentence type into which they may be inserted), and it is very likely that many aspects of this classification will be universally valid.

Case elements which are optionally associated with specific verbs,

nowhere overtly reflected as affixes or function words. The notion we are after probably corresponds to Meinhof's *Kasusbeziehungen*. (See Meinhof, 1938, p. 71.) The Meinhof reference, which I have not seen, was quoted in Frei (1954, fn. p. 31).

²⁶ It follows that whenever more than one case form appears in the surface structure of the same sentence (on different noun phrases), either more than one deep-structure case is involved or the sentence is complex. If, for example, German *lehren* is described as a verb which 'takes two accusatives', we have reason to believe that in the deep structure, the two object nouns are distinct as to case. Often enough the language will provide evidence for the distinction, as in the occurrence of such passive sentences as *das wurde mir gelehrt*.

together with the rules for forming subjects, will serve to explain various co-occurrence restrictions. For example, in 18 the subject is in an Agent relation to the verb; in 19 the subject is an Instrument; and in 20 both Agent and Instrument appear in the same sentence, but in this case it is the Agent which appears as the subject, not the Instrument.

- 18. John broke the window.
- 19. A hammer broke the window.
- 20. John broke the window with a hammer.

That the subjects of 18 and 19 are grammatically different explains the fact that the combined meaning of the two sentences is not produced by conjoining their subjects. Thus 21 is unacceptable.

- 21. * John and a hammer broke the window.

Only noun phrases representing the same case may be conjoined. Similarly, the fact that only one representative of a given case relationship may appear in the same simple sentence, together with the generalizations on subject selection and the redundancies which hold between cases and lexical features (for example, between Agent and animateness), explains the unacceptability of Sentence 22.

- 22. * A hammer broke the glass with a chisel.

It is unacceptable, in particular, on the interpretation that both *hammer* and *chisel* are understood instrumentally. It cannot represent a sentence containing an Agent and an Instrument, since the noun *hammer* is inanimate.²⁷

The dependency that can be accounted for by making these assumptions is that the subject of an active transitive sentence must be interpretable as a personal agent just in case the sentence contains a *with* phrase of instrumental import. Apparent exceptions to this generalization can be seen to have different underlying structures. Sentence 23 looks like an exception, but by attending to the effect of the word *its*, the essential difference between 23 and Sentences 22 and 24 becomes apparent.

²⁷ The author is aware that in Sentence 18 one might be talking about what John's body did as it was tossed through the window and that in Sentence 19 one might be speaking metaphorically, personifying *hammer*. Under either interpretation Sentence 21 turns out to be acceptable, and under the personification interpretation, Sentence 22 becomes acceptable. What is important to realize is that these interpretations, too, are explainable by reference to exactly the same assumptions appealed to in explaining their 'face value' interpretations.

- 23. The car broke the window with its fender.
- 24. * The car broke the window with a fender.

Sentence 24 violates the conditions that have been discussed, but Sentence 23 is a paraphrase of Sentence 25 and may be interpreted as having the same structure as 25.

- 25. The car's fender broke the window.

What is suggested here is that Sentences 23 and 25 are agentless sentences containing a *possessed noun* as the Instrument (*the car's fender*). The rules for choosing a subject allow an option in this case: either the entire instrument phrase may appear as the subject (as in 25), or the 'possessor' alone may be made the subject, the remainder of the instrument phrase appearing with the preposition *with* (as in 23). The second option requires that a 'trace' be left behind in the instrument phrase, in the form of the appropriate possessive pronoun. A similar explanation is suggested for such sentences as 26 and 27, which are also interpretable as deep structurally identical.

- 26. Your speech impressed us with its brevity.
- 27. The brevity of your speech impressed us.

The superficial nature of the notion 'subject of a sentence' is made apparent by these examples in a particularly persuasive way, because in the possessor-as-subject cases, the 'subject' is not even a major constituent of the sentence; it is taken from the modifier of one of the major constituents.

In the basic structure of sentences, then, we find what might be called the 'proposition', a tenseless set of relationships involving verbs and nouns (and embedded sentences, if there are any), separated from what might be called the 'modality' constituent. This latter will include such modalities on the sentence-as-a-whole as negation, tense, mood, and aspect.²⁸ The exact nature of the modality constituent may be ignored for our purposes. It is likely, however, that certain 'cases' will be directly related to the modality constituent as others are related to the proposition itself, as for example certain temporal adverbs.²⁹

The first base rule, then, is 28, abbreviated to 28'.

²⁸ There are probably good reasons for regarding negation, tense, and mood as associated directly with the sentence as a whole, and the perfect and progressive 'aspects' as features on the V. See for a statement of this position Lyons (1966, pp. 218, 223).

²⁹ In my earlier paper I suggested that sentence adverbials in general are assigned to the modality constituent. I now believe that many sentence adverbs are introduced from superordinate sentences (by transformations of a type we may wish to call 'infrjections'). This possibility has long been clear for unmistakable sentence adverbs like *unfortunately*, but there are also quite convincing reasons for extending the infrjection interpretation to adverbs like *willingly*, *easily*, and *carefully*.

28. Sentence \rightarrow Modality + Proposition
 28'. S \rightarrow M + P³⁰

The P constituent is 'expanded' as a verb and one or more case categories. A later rule will automatically provide for each of the cases the categorial realization as NP (except for one which may be an embedded S). In effect the case relations are represented by means of dominating category symbols.

The expansion of P may be thought of as a list of formulas of the form seen in 29, where at least one case category must be chosen and where no case category appears more than once.

29. P + V + C₁ + \dots + C_n

Whether these formulas can be collapsed according to the familiar abbreviatory conventions is not at present clear. For our purposes we may simply think of P as representable by any of a set of formulas including V + A, V + O + A, V + D, V + O + I + A, and so forth. (The letter symbols are interpreted below.)

The case notions comprise a set of universal, presumably innate, concepts which identify certain types of judgments human beings are capable of making about the events that are going on around them, judgments about such matters as who did it, who it happened to, and what got changed. The cases that appear to be needed include:

- Agentive* (A), the case of the typically animate perceived instigator of the action identified by the verb.³¹
Instrumental (I), the case of the inanimate force or object causally involved in the action or state identified by the verb.³²
Dative (D), the case of the animate being affected by the state or action identified by the verb.

³⁰ The arrow notation is used throughout, but this should not be interpreted as meaning that the proposal for a case grammar requires an assumption of a left-to-right orientation of the constituent symbols of the rewriting rules.

³¹ The escape qualification 'typically' expresses my awareness that contexts which I will say require agents are sometimes occupied by 'inanimate' nouns like *robot* or 'human institution' nouns like *nation*. Since I know of no way of dealing with these matters at the moment, I shall just assume for all agents that they are 'animate'.

³² Paul Postal has reminded me of the existence of sentences like

- i. I rapped him on the head with a snake.

The requirement that instrumental NP's are 'inanimate' is the requirement to interpret i as having in its underlying structure something equivalent to *with the body of a snake*. The fact that there are languages which would require mention of a stem meaning 'body' in this context may be considered as support for this position, and so may the unacceptability, pointed out by Lakoff, of sentences like ii:

- ii. * John broke the window with himself. (See Lakoff, 1967.)

Factitive (F), the case of the object or being resulting from the action or state identified by the verb, or understood as a part of the meaning of the verb.

Locative (L), the case which identifies the location or spatial orientation of the state or action identified by the verb.

Objective (O), the semantically most neutral case, the case of anything representable by a noun whose role in the action or state identified by the verb is identified by the semantic interpretation of the verb itself; conceivably the concept should be limited to things which are affected by the action or state identified by the verb.³³ The term is not to be confused with the notion of direct object, nor with the name of the surface case synonymous with accusative.

Additional cases will surely be needed. Suggestions for adding to this list will appear in various places below.

It is important to notice that none of these cases can be interpreted as matched by the surface-structure relations, subject and object, in any particular language. Thus, *John* is A in 29 as much as in 30; *the key* is I in 31 as well as in 32 or 33; *John* is D in 34 as well as in 35 and 36; and *Chicago* is L in both 37 and 38.

29. John opened the door.
 30. The door was opened by John.
 31. The key opened the door.
 32. John opened the door with the key.
 33. John used the key to open the door.
 34. John believed that he would win.
 35. We persuaded John that he would win.
 36. It was apparent to John that he would win.
 37. Chicago is windy.
 38. It is windy in Chicago.

The list of cases includes L, but nothing corresponding to what might be called directional. There is a certain amount of evidence, as was mentioned above, that locational and directional elements do not contrast but are superficial differences determined either by the constituent structure or by the character of the associated verb. An example provided by Hall (39) suggests, by the occurrence of the pro replacement word *there*, that *to the store* and *at the store* are variants of the same

³³ In Fillmore (1966a) the neutral case was unwisely and misleadingly labeled 'ergative'.

entity, determined by the movement or nonmovement character of the associated verb.³⁴

39. She took him to the store and left him there.

I have stated that A and D are 'animate' participants in the activity of the associated verbs, and I have also suggested that verbs are selected according to the case environments the sentence provides—what I shall refer to as the 'case frame'. There are, then, the two problems of lexical selection, that of the nouns and that of the verbs. Those features of nouns required by a particular case are to be specified by obligatory rules of the type such as the following, which specifies that any N in an A or D phrase must contain the feature [+animate]. (Recall the qualification of Footnote 30.)

$N \rightarrow [+animate]/^{A,D} [X \text{ — } Y]$

To take care quite generally of lexical features associated with specific cases, we may appeal to a rule which associates with each noun a

³⁴ Hall (1965).

The putative contrast between locational and directional expressions as well as the distinction between 'optional' and 'obligatory' locative expressions, as exemplified in Hall's examples i and ii, seem to point to the difference between elements which are 'inside the VP' and elements which are 'outside the VP'.

- i. John keeps his car in the garage.
- ii. John washes his car in the garage.

In our terms this would be equivalent either to determining whether there is a difference between an L as a constituent of P and an L as a constituent of M, or whether there can be two L elements within P, distinguished in terms of degree of selectivity of verbs. The highly restricting L selects verbs like *keep*, *put*, and *leave*, but not *polish*, *wash*, and *build*; the weakly restricting L selects verbs like *polish*, *wash*, and *build*, but not *believe*, *know*, or *want*.

However this distinction is interpreted, the second or 'outer' L is in some respects similar in its 'selectional' properties to what might be called the *benefactive* case B. B, too, is involved in the selection of verbs in the sense that some verbs do not accept B modification (*'He is tall for you'); but the restriction here may have more to do with *dependency relations between cases* than with dependencies directly connected with the verb. It appears, in fact, that those verbs which allow 'outer L' and B modification are precisely those which take agents. I have no ideas on how these dependencies can be stated, but it would appear that the second L and the B can appear only in sentences containing A's.

Thus the *regime direct* versus *regime indirect* interpretation of the difference between iii and iv

- iii. *Il demeure à Paris.*
- iv. *Il travaille à Paris.*

may have simply to do with the fact that the subject of iv is actually an A. Both the specific verb and the occurrence of an 'outer L' are determined by the presence of an A. See, in this connection, Bazell's discussion (1949, p. 10) of Gougenheim's review of de Boer's French syntax.

label identifying the case relation it holds with the rest of the sentence. Such a rule might associate with every noun under L the feature [+locative], for example. Since abstract nouns such as *idea* cannot serve as heads of L expressions, they will be marked [−locative].³⁵

The insertion of verbs, on the other hand, depends on the particular array of cases, the 'case frame', provided by the sentence.³⁶ The verb *run*, for example, may be inserted into the frame [— A], the verb *sad* into the frame [— D], verbs like *remove* and *open* into [— O + A], verbs like *murder* and *terrorize* (that is, verbs requiring 'animate subject' and 'animate object') into [— D + A], verbs like *give* into [— O + D + A], and so on.

In lexical entries for verbs, abbreviated statements called 'frame features' will indicate the set of case frames into which the given verbs may be inserted. These frame features have the effect of imposing a classification of the verbs in the language. Such a classification is complex not only because of the variety of case environments possible within P, but also because many verbs are capable of occurring in more than one distinct case environment. This last fact can be represented most directly by allowing facultative representation of cases in the frame-feature expressions.

The word *open*, to take a familiar example, can occur in [— O], as in 40; in [— O + A], as in 41; in [— O + I], as in 42; and in [— O + I + A], as in 43.

40. The door opened.
41. John opened the door.
42. The wind opened the door.
43. John opened the door with a chisel.

The simplest representation of this set of possibilities makes use of parentheses to indicate the 'optional' elements. The frame feature for *open* may thus be represented as 44.

44. +[— O (I) (A)]³⁷

³⁵ By allowing highly restricting lexical features to be associated with given case units we have returned to that extension of 'cases' to 'adverb forms' proposed by Bopp, Wüllner, and Hartung. Some adverbs, on this view, are really nouns capable of 'taking' only one case form. Since deep structure cases are in fact all 'defective' to some extent, with respect to the nouns which they accept, such a concept as *inflectional scope* no longer provides a clear demarcation between 'case forms proper' and 'adverbs'. See the discussion of this question in Hjelmslev (1935, p. 40).

³⁶ I am adhering, in this discussion, to the Postal-Lakoff doctrine, which I find thoroughly convincing, that adjectives constitute a subset of verbs.

³⁷ Case frames are represented in square brackets, with 'underline' indicating the position of the element with respect to which the expression is an environmental frame.

Other verbs having this same feature are *turn*, *move*, *rotate*, and *bend*.

For a verb like *kill* it is necessary to indicate, expressing it in familiar terms, that it takes an animate object and either an animate or an inanimate subject, and that if there is an animate subject, an instrument phrase may also co-occur. The frame feature for *kill*, in other words, will have to specify that either an Instrument or an Agent must be specified, and both may be specified. If the linked parentheses notation can be introduced to indicate that at least one of the linked elements must be chosen, the frame feature for *kill* can be given as 45.

45. +[____ D (I(A))]

The verb *murder*, on the other hand, is one which requires an Agent. Its frame feature differs from that of 44 and 45 because the element A is obligatorily present. It is given as 46.

46. +[____ D (I) A]

The environmental subclassification of verbs is sensitive to more than the mere array of cases in *P*. Since one of the cases may be represented by *S* (an embedded sentence), verbs are also subclassified in terms of whether the O element is a sentence. By convention we shall interpret the symbol O in frame features as indicating NP's, and the symbol S as indicating an O to which an S has been embedded.

The frame feature +[____ S] characterizes such verbs as *true*, *interesting*, and so forth; the feature +[____ S + D] is common to such verbs as *want* and *expect*; verbs like *say*, *predict* and *cause* appear in the frame [____ S + A]; and verbs like *force* and *persuade* are insertable into the frame [____ S + D + A].³⁸

Verbs are distinguished from each other not only by specification of the case frames into which they can be inserted, but also by their transformational properties. The most important variables here include (a) the choice of a particular NP to become the surface subject, or the surface object, wherever these choices are not determined by a general rule; (b)

A frame feature is represented in square brackets with '+' or '-' in front, indicating that the set of case frames represented by the expression within the brackets is that which will (if the feature is marked '+') or which will not (if the feature is marked '-') accept the lexical item with which the feature is associated.

³⁸ It should be pointed out that descriptions of embedded sentences as *it* + *S* realizations of the category NP in 'subject/object' grammars must somehow guarantee that this particular expansion of NP is limited to the subjects of intransitive sentences and the objects (direct or oblique) of transitive sentences. All such restrictions are rendered unnecessary by the decision to limit complement S to the case element O.

the choice of prepositions to go with each case element, where these are determined by idiosyncratic properties of the verb rather than by a general rule; and (c) other special transformational features, such as, for verbs taking S complements, the choice of specific complementizers (*that*, *-ing*, *for to*, and so forth) and the later transformational treatment of these elements.

The use of parentheses in expressing the frame features, together with the transformational introduction of subjects, makes it possible to reduce the number of semantic descriptions in the lexicon. The semantic interpretation of a P will introduce all information provided by specific case relationships represented in the P, allowing such information to be omitted from the semantic descriptions of verbs. In the case of verbs having the feature 44, as we have seen, certain related transitive and intransitive verbs need not be given separate semantic description. This point may be further demonstrated with the English verb *cook*. The frame feature of *cook* is presumably something like 47

47. +[____ O (A)]

and an idiosyncratic transformational feature of the verb is that just in case the A is present and the O is some NP representing a typical NP for the verb (that is, something like *food* or *a meal*), the O element may be deleted. The semantic description of the verb will do no more than identify a particular activity having a result of a particular kind on the object identified by the O element. The same semantic entry, in other words, will account for the use of *cook* in all of the sentences 48-50.

48. Mother is cooking the potatoes.

49. The potatoes are cooking.

50. Mother is cooking.

Instead of saying that the verb has three different meanings, we can be satisfied to say that there is a certain variety in the case frames which accept it, and that it is one of the 'deletable object' verbs. The fact that A is obligatorily animate and that O is unspecified for animateness accounts for the fact that if we can read Sentence 49 as ambiguous, it is because we can accept certain violations of grammatical requirements in 'personifications' of the type we have learned in nursery school, whereas if we accept 50 as in fact ambiguous, it is because we are acquainted with the range of activities found in human societies.

The example with *cook* shows that the lexicon need not contain as many semantic entry *tokens* under the present proposal as it would in

a subject/object grammar.³⁹ It will now be shown that this same flexibility makes it possible to reduce the number of semantic entry *types*, for now it is feasible to show that some syntactically different words are in fact semantically identical (with respect to that aspect of their meanings which is independent of the contribution of the associated cases). This may be true for verbs like *like* and *please*, to give the example that comes most quickly to mind. These words may be described as being synonymous. Each has the frame feature $+[\text{---} \text{O} + \text{D}]$; they differ only in their subject selection features. The verb *like*, in fact, has in its history the subject selection feature possessed by *please*.

The verb *show*, to give another kind of example, might well have the same semantic representation as *see*, differing from it only in that the frame feature for *show* contains an A where that for *see* does not. The verbs *kill* and *die* appear to be related in a similar way.

51. *see* ($+[\text{---} \text{O} + \text{D}]$) versus *show* ($+[\text{---} \text{O} + \text{D} + \text{A}]$)
 52. *die* ($+[\text{---} \text{D}]$) versus *kill* ($+[\text{---} \text{D} (\text{I})\text{A}]$)

We have seen, then, instances of synonymy where there are identical frame features but different subject selection features, and instances of synonymy where there are frame feature differences depending on whether a particular case category was present or absent. We may now turn to examples of synonymy where the difference is in the choice of one case or another.

It will be recalled that both A and D are animate. The semantic descriptions of certain verbs may refer to the animateness of the associated noun, independently of whether the 'source' of the animateness is A or D. That is, the semantic representation of certain verbs may specify a

³⁹ It may appear that facultative representation of cases in frame features has the advantages it does in English because there are so many verbs which can be used transitively or intransitively in the same form. It is a language-particular coincidence that English uses the same form in these words. The identification of transitive and intransitive *open*, or transitive and intransitive *cook*, is justified because the semantic characterization of the verb is the same in all of the uses discussed. (We must distinguish between the semantic characterization of a verb and the semantic interpretation of sentences containing the verb. In the latter case, all of the co-constituents and the semantic role they play as determined by their cases are taken into account.) Wherever that condition can be satisfied, facultative representation is called for. It will turn out that for some languages the occurrence or nonoccurrence of one of the 'optional' cases will have an effect on the verb. If, for verbs of the type $[\text{---} \text{O} (\text{A})]$, the appearance of the A determines a variant of the verb different from that when A is missing (distinguishing the 'transitive' from the 'intransitive' use of the 'same' verb), or if the absence of the A requires some additive element (for example, a 'reflexive' morpheme) not needed when the A is expressed, these facts can be provided transformationally. See Hashimoto (1966). (By extending the range of acceptable surface variants of verbs under these conditions to suppletion, it may even be possible to interpret the contrasts exemplified in 51-53 below as surface lexical variation.)

relationship or a process associated with the necessarily animate participant in the state or activity identified by the verb. The relation of *hear* and *listen* to the necessarily animate NP is the same in both cases; the difference in the semantic interpretation of the P's containing them is determined by the semantic contribution of the associated cases and by the fact that the frames that contain *hear* are $[\text{---} \text{O} + \text{D}]$ and those that contain *listen* are $[\text{---} \text{O} + \text{A}]$. The fact that in the case of *listen* the relationship is understood as involving the active participation of the person identified as A is due to the presence of A, not to a special meaning of *listen*. The same distinction can be seen between *see* and *know*, on the one hand, and *look* and *learn*, on the other.

53. *see, know* ($+[\text{---} \text{O} + \text{D}]$) versus *look, learn* ($+[\text{---} \text{O} + \text{A}]$)

This latest point leads one to those properties of English verbs with which Lakoff (1966) associates the terms 'stative' and 'nonstative'. The question we need to ask is whether Lakoff's features are primitives in the lexical entries for verbs, or whether they permit reduction to concepts of the type I have been outlining. Lakoff has noticed that the 'true imperative', the progressive aspect, the occurrence of benefactive (B) phrases, and *do so* substitution occur only with 'nonstative' verbs. His discussion suggests that one must assign 'stative' and 'nonstative' as features on verbs and then guarantee that B phrases are permitted only with 'nonstatives' (put the other way around, one must guarantee that the presence of a B expression allows only for the selection of 'nonstatives'), that the imperative transformation can be applied only if the verb is 'nonstative', and so on. The treatment that I prefer is implicit in what I have already presented. The transformation which accounts for the 'true imperatives' can apply only to sentences containing A's, and the occurrence of B expressions (and 'outer L's') is dependent on the presence of an A. The progressive aspect can only be chosen in association with particular case frames, for example, those containing A's. No special features indicating stativity need be added to verbs because, if this suggestion is correct, only those verbs which occur in P's containing A's will show up in these sentences anyway.⁴⁰

3.5 Surface Phenomena

To recapitulate, our discussion so far has suggested that the deep structure of (the propositional component of) every simple sentence is

⁴⁰ The *do-so* evidence is not so easy to interpret in this way. Still, the connection between 'nonstative' verbs and verbs that can 'take' A is too compelling to be simply wrong.

an array consisting of a V plus a number of NP's holding special labeled relations (cases) to the sentence. These relations, which are provided for categorially, include such concepts as Agentive, Instrumental, Objective, Factive, Locative, Benefactive, and perhaps several others. Complex sentences involve recursion through the category Sentence under the case category Objective. Verbs are subclassified according to the case environments which accept them, and the semantic characterizations of verbs relate them either to specific case elements in the environment or to elements containing features (such as animateness) introduced as obligatory accompaniments of particular cases.

This section will deal with some of the ways in which deep structures of the type proposed in this essay are converted into surface representations of sentences. The various mechanisms involve selection of overt case forms (by suppletion, affixation, addition of prepositions or postpositions), 'registration' of particular elements in the verb, subjectivalization, objectivalization, sequential ordering, and nominalizations.

A surface case system may be related to the set of underlying cases in a variety of ways. Two deep cases may be represented in the same way in the surface structure, as when D and O direct objects are both represented with the 'accusative' case in many languages (where the determining factor may be occurrence immediately after the verb at some stage of derivation). A and D may be represented by the same overt form, where the determining factor may be case-linked animateness. Or the superficial form of a case element may be determined by an idiosyncratic property of some governing word.

The rules for English prepositions may look something like this: the A preposition is *by*; the I preposition is *by* if there is no A, otherwise it is *with*; the O and F prepositions are typically *zero*; the B preposition is *for*; the D preposition is typically *to*; the L and T (for time) prepositions are either semantically nonempty (in which case they are introduced as optional choices from the lexicon), or they are selected by the particular associated noun [*on the street*, *at the corner* (=intersection of two streets), *in the corner* (of a room); *on Monday*, *at noon*, *in the afternoon*]. Specific verbs may have associated with them certain requirements for preposition choice that are exceptions to the above generalization.⁴¹

The position of prepositions can be guaranteed either by having the

⁴¹ The verb *blame*, for example, chooses ('governs') *for* for O and *on* for D. The O preposition is *at* for *look* meaning 'examine', *for* for *look* meaning 'seek', *to* for *listen*, and so forth. Changes in the original preposition assignment may be brought about by transformations: the rules which provide surface subjects and direct objects delete prepositions (replace them by zero), and the rules which form deverbal (= desentential) nominals convert some of the original case forms into 'genitive', either by replacing the assigned preposition with *of*, or, in some cases, by removing the original preposition and affixing the 'genitive' suffix.

case categories rewritten as *Prep + NP*, or by having *Prep* be one of the obligatory constituents of NP. I shall make the former choice, although the grounds for deciding one way or the other are not particularly clear. The 'universal' character of the base rules is kept intact by the assumption that prepositions, postpositions, and case affixes—semantically relevant or not—are all in fact realizations of the same underlying element, say *K* (for *Kasus*). We may regard all of the case categories as therefore rewritten as *K + NP*.

Every English sentence has a surface subject, if only formally so. For most combinations of cases there is a 'preferred' or 'unmarked' subject choice; for some there is no actual choice—the subject is uniquely determined. In general the 'unmarked' subject choice seems to follow the following rule:

54. If there is an A, it becomes the subject; otherwise, if there is an I, it becomes the subject; otherwise, the subject is the O.

Suppose, for example, that the base representation of a particular sentence is item 55:

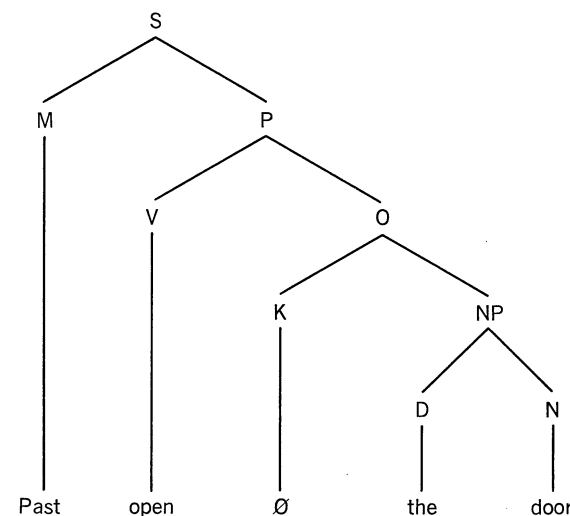

Since the sentence contains only one case category, it is obligatorily moved to the front (and hence directly subjoined to the category S) where it will later undergo subject-preposition deletion. There is a stage, in other words, where the form of the sentence in question is that represented in 56.

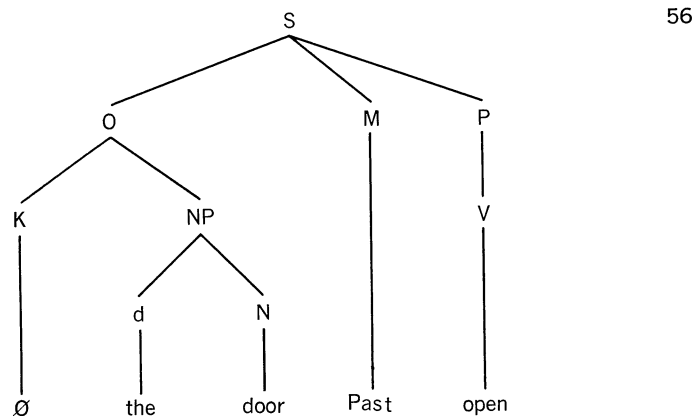

The subject-preposition deletion rule removes the preposition and deletes the case label. After application of the subject-preposition deletion rule, the form of the sentence is that represented in 57.

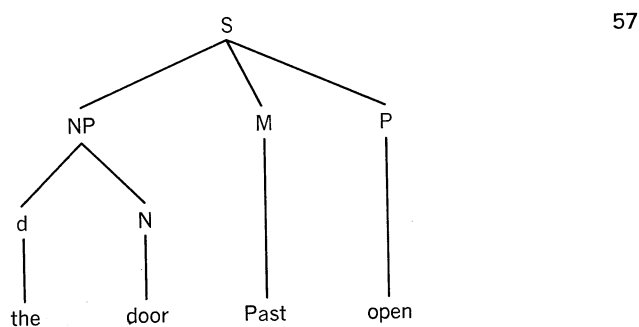

The final surface form, shown in 58, results from incorporation of the tense into the verb.

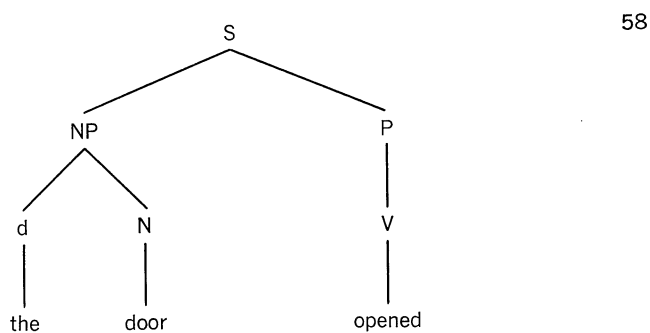

For a base configuration containing an A, a distinction must be made

between the 'normal' and the 'nonnormal'⁴² choice of subjects. The choice of the A as the subject, in accordance with the rule proposed in 54 above, requires no modification of the verb. The changes from 59 to 60 represent subject-fronting, those from 60 to 61 show subject-preposition deletion, and those from 61 to 62 indicate the effect of a third rule, object-preposition deletion.⁴³ The eventual surface structure of the sentence whose deep structure is 59 is 63.

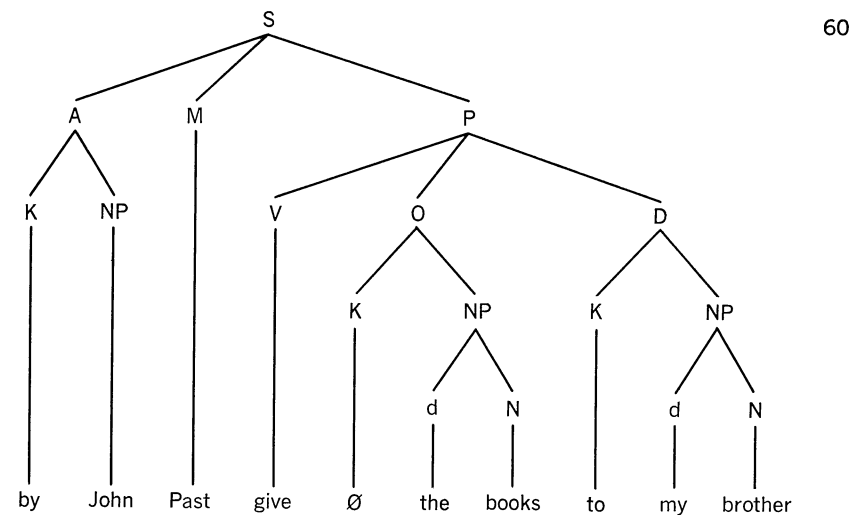
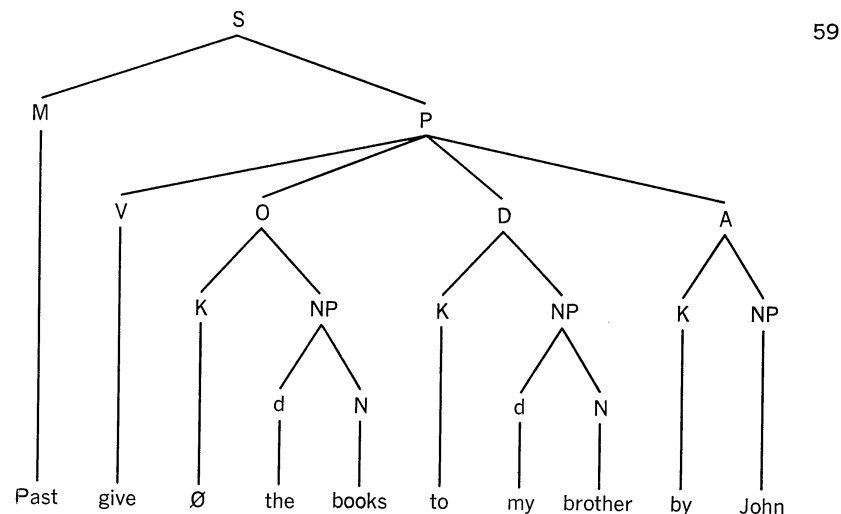

⁴² The choice of terms is not to be taken seriously.

⁴³ Verbs are categorized according to whether they delete the preposition of the following case category, that is, whether they 'take on' a direct object. The object-preposition deleting property of a verb may be modified by a transformation.

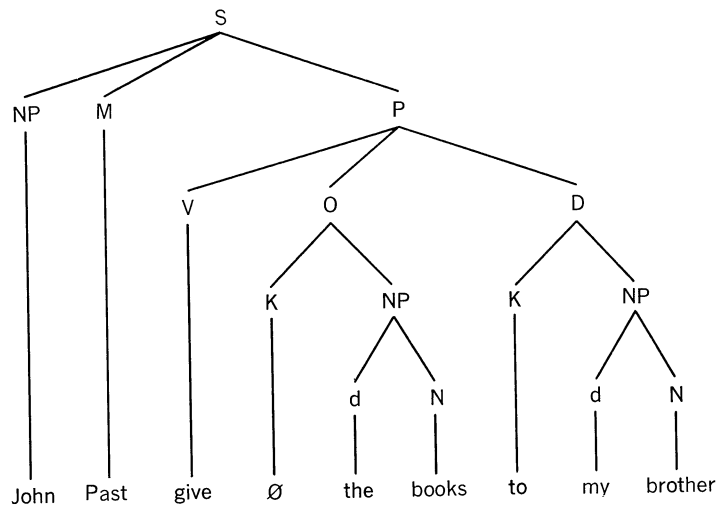

61

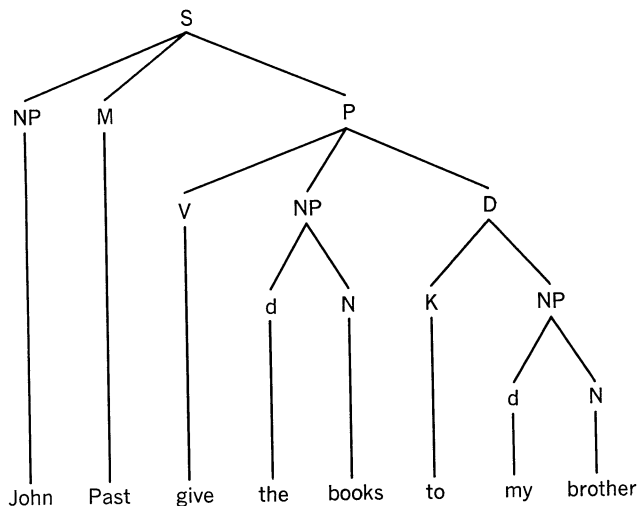

62

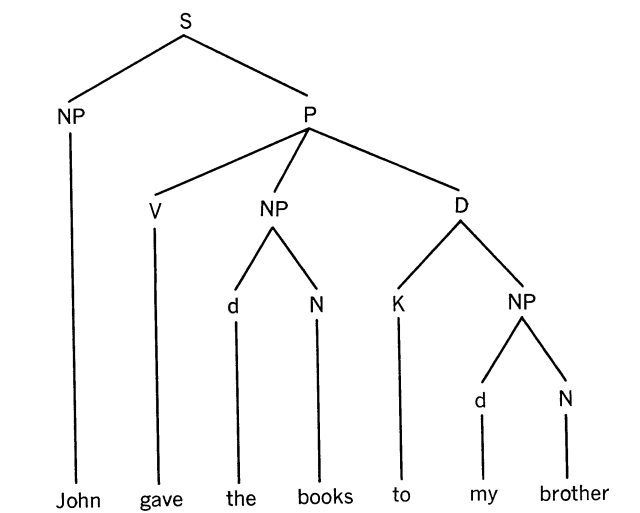

63

36

If it is noted that the verb *give* is one which, with A as subject, allows either O or D to become the direct object, an alternative surface form for 59 is 64 (assuming that case-label deletion occurs when zero K elements are 'deleted').

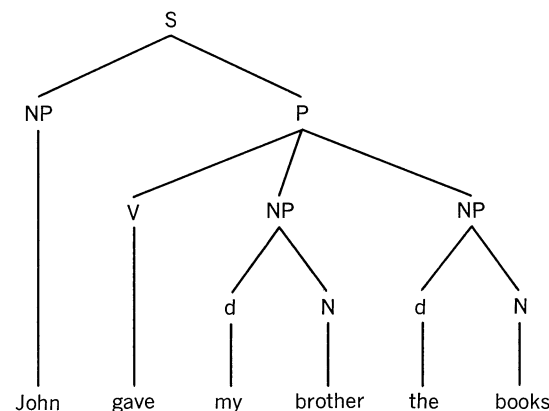

64

The 'normal' choice of subject for sentences containing an A, as stated in generalization 54 (which is a generalization for English), is the A. The verb *give* also allows either O or D to appear as subject as long as this 'nonnormal' choice is 'registered' in the V. This 'registering' of a 'nonnormal' subject takes place via the association of the feature [+passive] with the V. This feature has three effects: the V loses its object-preposition deletion property, it loses its ability to absorb the tense (requiring the automatic insertion of a *be* in the M constituent), and it must now be filled by a special 'passive' form (that is, *given*). The sequence 65 to 68 develops the choice of O as subject, and the sequence 69 to 73 shows the result of choosing D as subject.

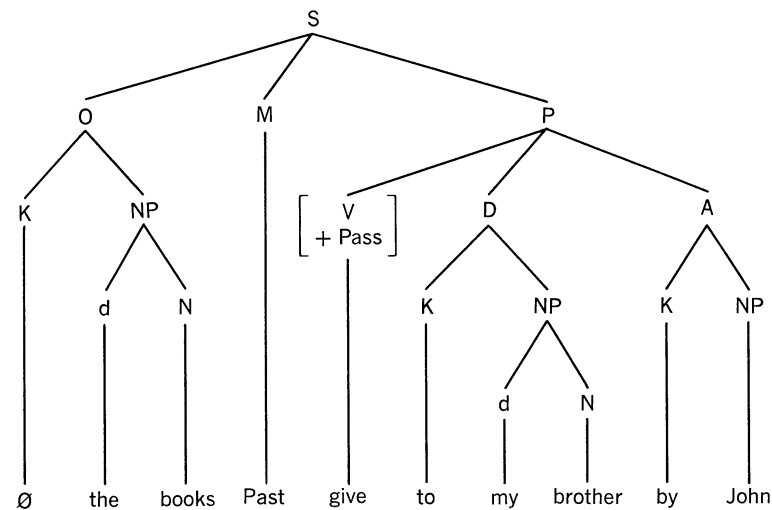

65

37

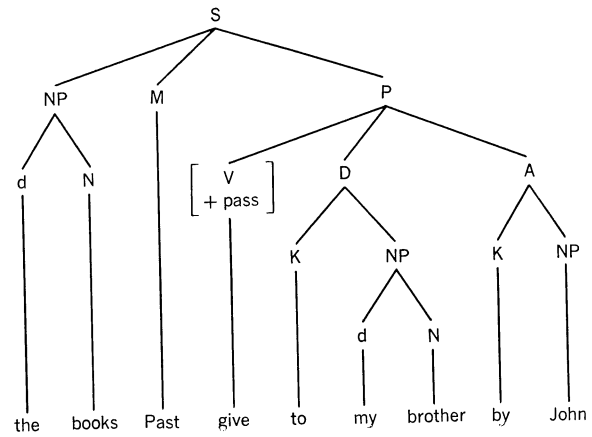

66

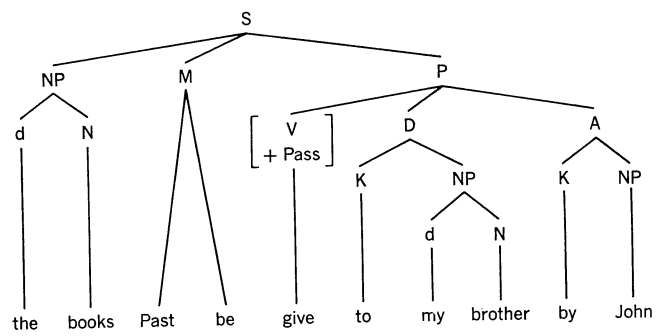

67

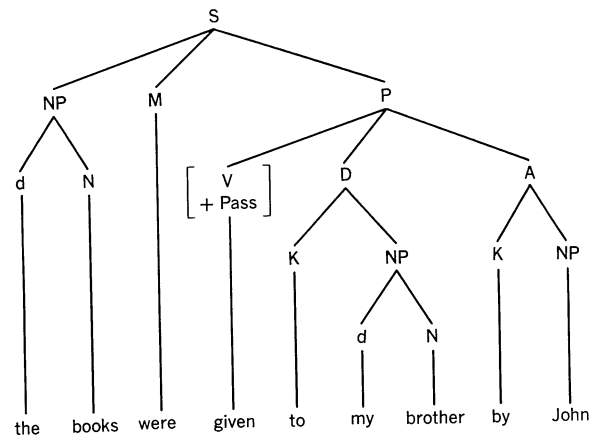

68

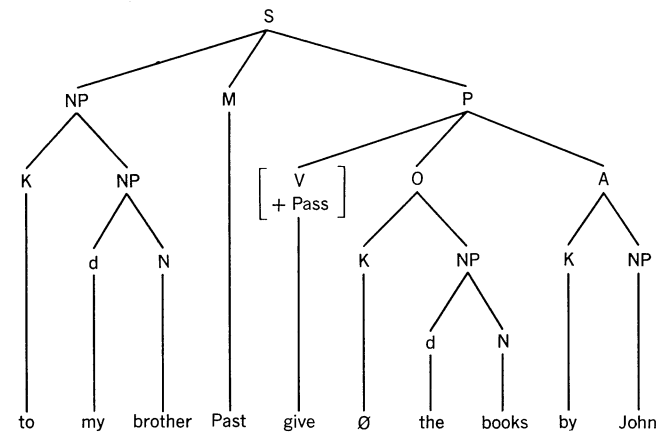

69

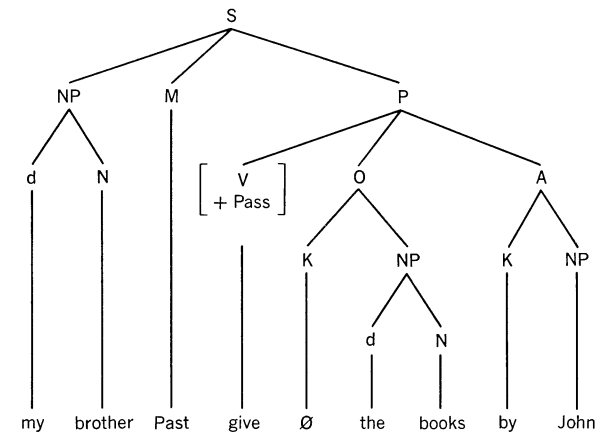

70

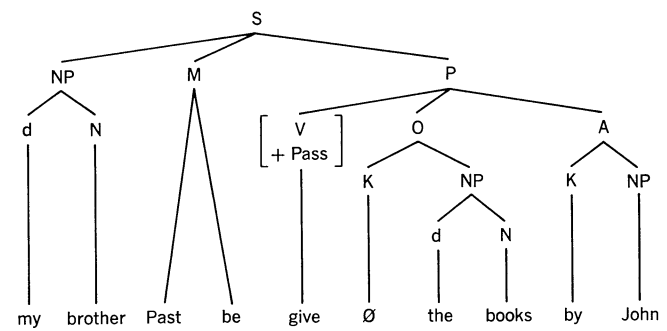

71

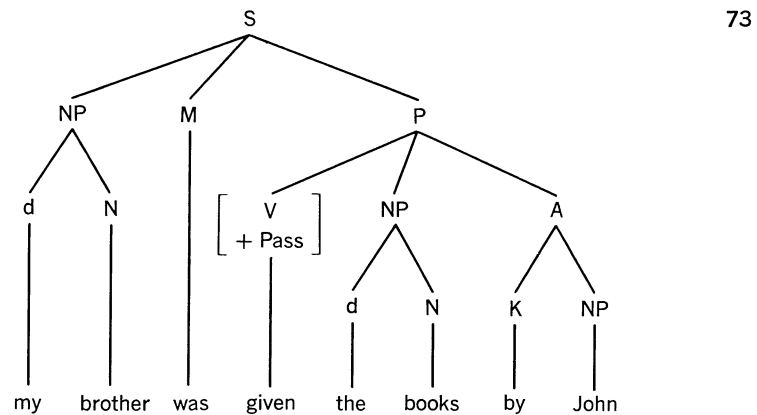
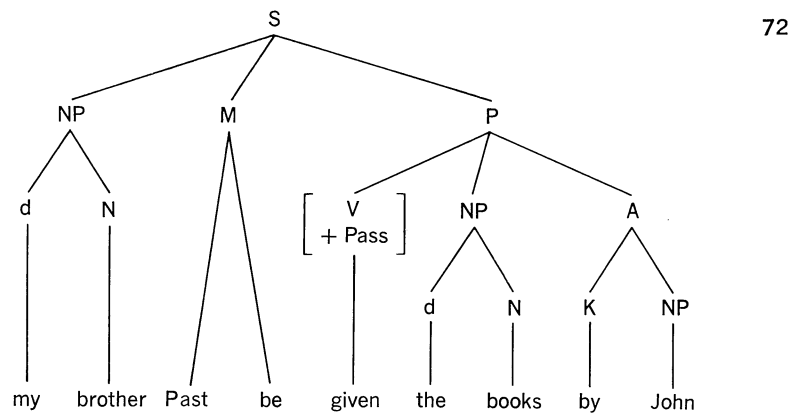

We have seen that where there is only one case category, its NP must serve as the surface subject. Examples 59 to 73 have shown ways of dealing with sentences containing more than one case category where one designated case could provide the subject without effecting any change in the V, or others could do so as long as a 'record' of this decision was attached to the V.

For many of the verbs which 'take' more than one case category, the one which contributes the subject is indicated by the verb itself. Of the verbs which are accepted into the frame [— O + D], *please*, *belong*, *interesting*, and others choose O as subject, and *like*, *want*, *think*, as well as others, choose D.⁴⁴

⁴⁴ As mentioned above, by regarding the differences here as representing no more than idiosyncratic facts about the syntactic properties of these verbs, we can accept historical changes like those with *like*, *want*, and *think* from verbs of the type which choose O to verbs of the type which choose D to be merely a matter of detail in the subject-selection processes in our language. In other words, we do not need to agree with

Sometimes subjects are created not by moving one of the case elements into the 'subject' position, but by *copying* a particular element into that position. This seems to be a consequence of the positional treatment of subjects in English and to be related to the use of purely formal subjects.⁴⁵

Copying for pro replacement can be illustrated with *that* clauses. The 'verb' *true* occurs in the frame [— S], that is, as in Configuration 74.

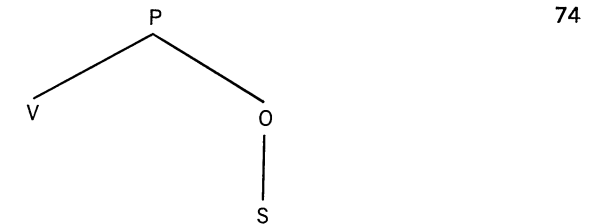

Since there is only one case element, it is obligatorily the subject. The context requires that the complementizer *that* be provided for the embedded sentence. By subject copying, 76 is derived from 75.

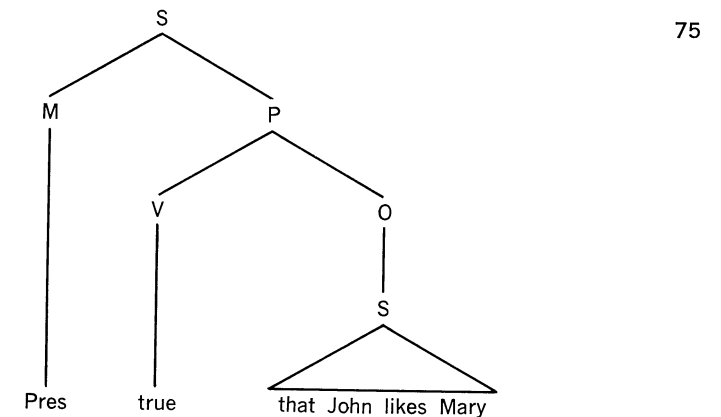

Jespersen when he describes the change in English from the use of expressions of the type 'him like oysters' to those of the type 'he likes oysters' as reflecting a change in the 'meaning' of the verb *like* from something like 'to be agreeable to' to something like 'to take pleasure in' (Jespersen, 1924, p. 160). The change seems merely to be a result of the inter-influencing of the two surface processes of choosing the first word and establishing verbal concord.

⁴⁵ From the fact that there may be only one case in a simple sentence, it becomes possible to allow all subjects to be formed by a copying transformation. Sentences with two copies of the same NP in the same case undergo one of a number of changes: the second copy is either deleted or replaced by a pro form, or the first copy is replaced by a pro form.

76

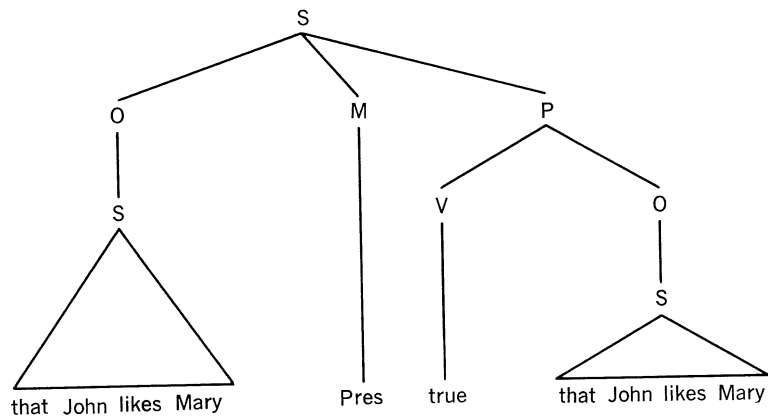

The structure of 76 undergoes either second copy deletion, yielding 77, or first copy pro replacement, giving us 78.

77

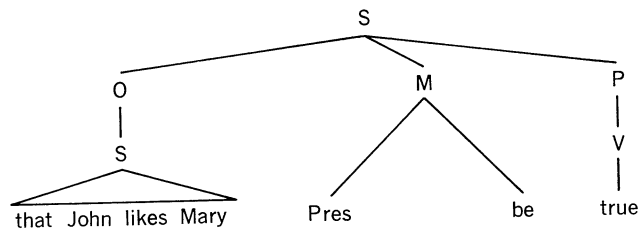

78

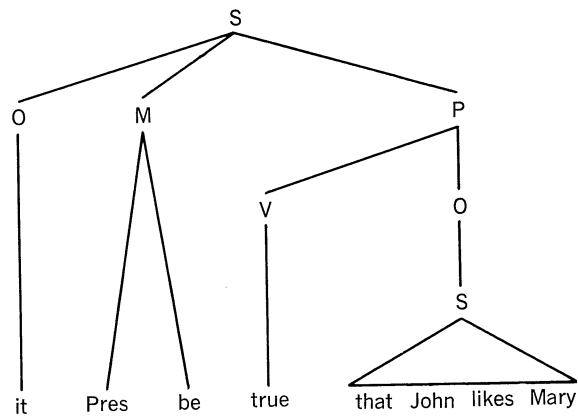

Verbs expressing meteorological conditions have the frame feature +[— L]. Choosing *hot* in that frame, we can construct the sentence whose deep structure is represented by 79. From 79 we get, by subject copying, item 80. By second copy deletion (and subject-preposition dele-

tion) item 80 becomes 81; on the other hand, if the first copy is replaced by its pro form (in this context, *it*), the resulting sentence is 82.⁴⁶

79

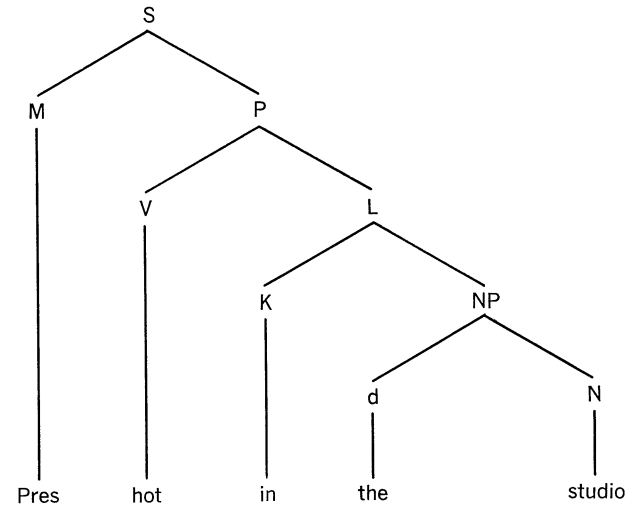

80

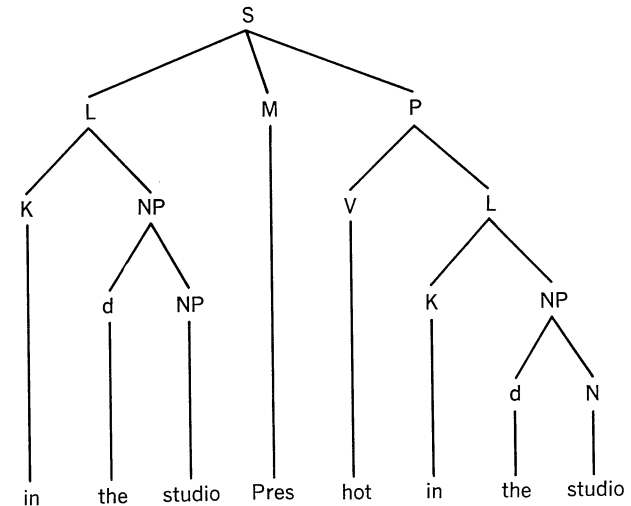

⁴⁶ It is likely that the correct analysis of subject copying is a little different from this. There is considerable evidence that when the first copy is replaced by its pro form, the second copy is actually outside of P, that is, that it is 'extraposed' in the sense of Rosenbaum. If this is true, then since the sentences having undergone extraposition must be created in two steps anyway, it is likely that the sentential subjects are formed in the usual way—not by copying—and that they are later extraposed, leaving behind, in the subject position, a 'trace' in the form of expletive *it*.

The examples and the analysis of meteorological verbs are adapted from Langendoen (1966).

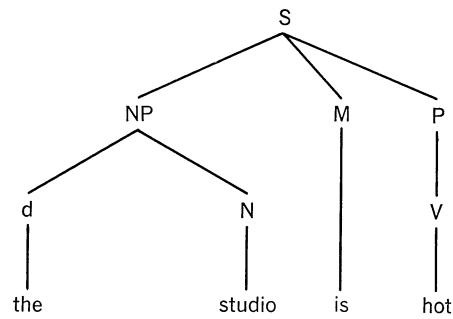

81

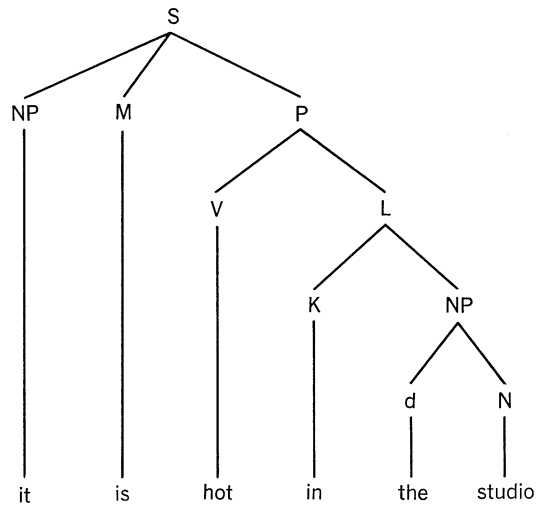

82

Under certain conditions, a first copy L may be replaced by an expletive *there*. The case frame [— O + L] may be filled by a blank verb (that is, zero). This situation (of verbless sentences) may call for the introduction of the element *be* into the M constituent, which is a process we have already seen to be necessary for verbs which are adjectives as well as for verbs which have been modified through addition of the feature [+passive]. For verbless sentences of the type [— O + L], the 'normal' subject choice is O. Thus from 83 we get 84, and eventually 85.

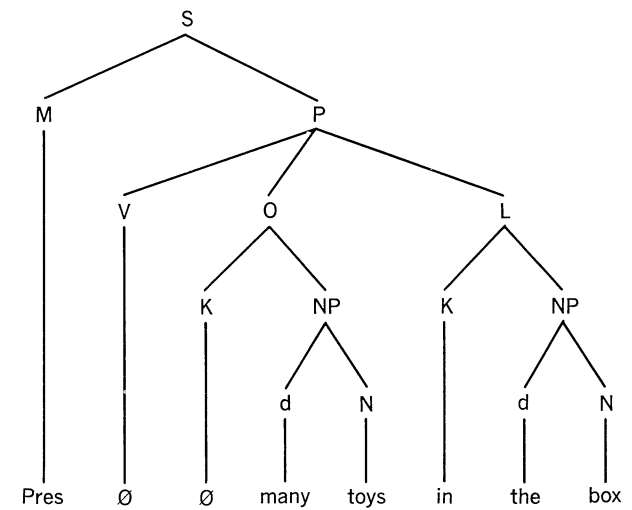

83

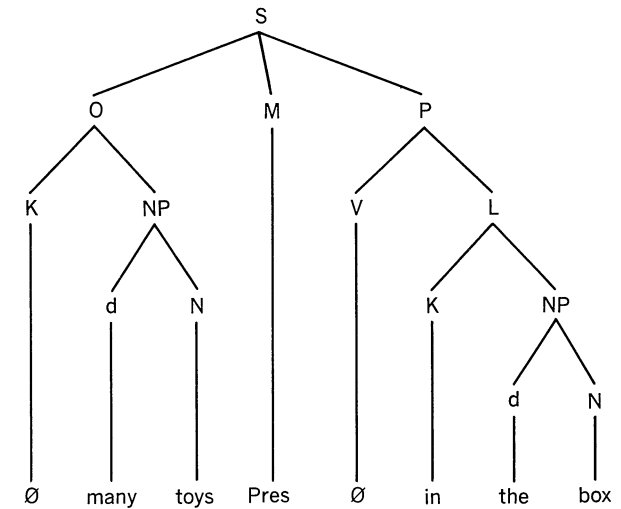

84

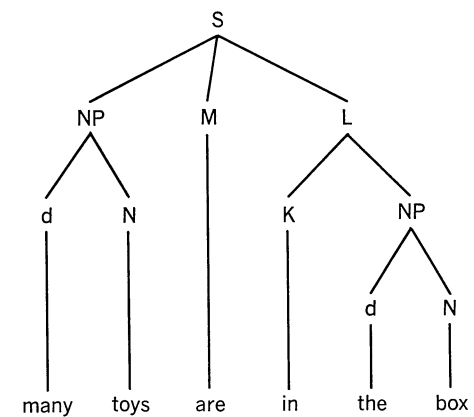

85

An alternative subject choice, through subject copying, is the L. Thus from 83 we might get 86.

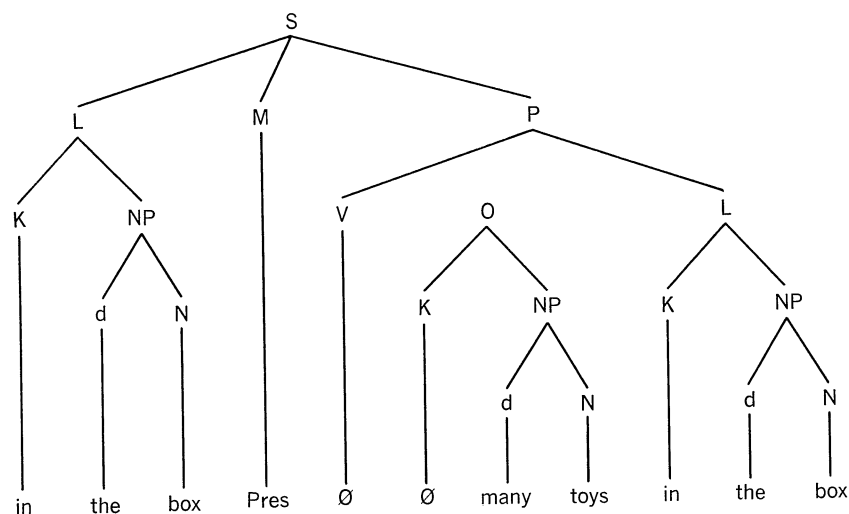

The pro form for L in verbless sentences is expletive (unstressed) *there*. The result of modifying 86 by pro replacement of the subject L is 87; extraposition of the second copy L, as suggested in footnote 45, has been carried out in 87.

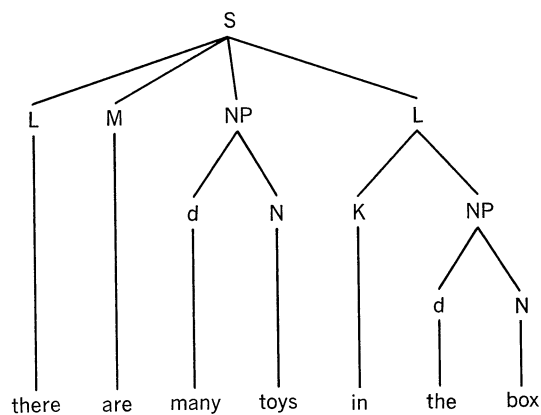

An alternative to replacing the first copy L by expletive *there* is to retain the L NP as subject. This decision requires the regular pronominalization of the repeated NP. It further requires modification of the verb: the

hitherto empty V position is filled with the function verb *have*.⁴⁷ Since *have* is a V, it is capable of absorbing the tense, making the addition of *be* to M no longer necessary. The result of choosing the first L as subject results, through subject-preposition deletion, *have* insertion, object-preposition deletion, repeated NP pronominalization, and tense affixation, in 88.

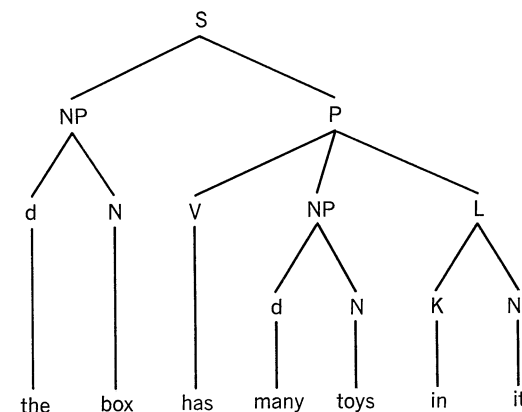

The general position I am taking on the verb *have* is that in verbless sentences (that is, when the V constituent is present but lexically empty) *have* is obligatorily inserted just in case the subject is an NP which is not from the case O. The most obvious case is that of the empty verb in the frame [— O + D], a context which in English requires D to be the subject, resulting in the typical *have* sentences. Other languages, for example, French, seem to have contexts in which the subject choice is optional—situations where *X a Y* is in a paraphrase relation with *Y est à X*. Other languages, for example, Estonian, do not have anything equivalent to the verb *have*.⁴⁸

Some languages have subjectivalization processes; and, as I have suggested for English, there seems to be an analogous objectivalization process which has the superficial effect of bringing a particular nominal element into closer association with the verb.

The formal rather than purely notional character of the direct object was noticed by Jespersen. His examples (1924, p. 162) show intra-language paraphrase relations like that between 89 and 90, and cross-language differences like that between 91 and 92.

⁴⁷ For a recent argument on the transformational introduction of *be* and *have* in all of their occurrences, see Bach (1967). For a more adequate treatment of existential sentences than I have presented, see especially Lee (1967).

⁴⁸ Another situation for introducing *have* to account for connections between such pairs of sentences as i and ii is discussed below in the section on inalienable possession.

- i. My knee is sore.
- ii. I have a sore knee.

89. present something to a person
 90. present a person with something
 91. furnish someone with something
 92. *fournir quelque chose à quelqu'un*

When such phenomena were examined by Hall, she took one form as basic, the other as derived. 'Derived subjects', in her analysis, are possible just in case there is no 'deep subject'; 'derived objects', on the other hand, have the effect of displacing the original deep-structure object and attaching a *with* to it. Her examples include 93-94 and 95-96.

93. John smeared paint on the wall.
 94. John smeared the wall with paint.
 95. John planted peas and corn in his garden.
 96. John planted his garden with peas and corn.

Hall provides rules which move the locative element (*the wall* or *his garden* of 93 and 95 respectively) into the direct object position by a transformation which also attaches *with* to the former direct object.

From the point of view taken here, it would be just as easy to say that both *on the wall* and *with paint* were initially provided with prepositions (as L and I case elements), the verb *smear* having the property that whichever of these elements is chosen as 'direct object' must fall next to it and must lose its preposition. (In other languages, the process might be expressed as converting an original case specification to 'accusative'.)⁴⁹

⁴⁹ There are semantic difficulties in treating subject and object transformationally, in the sense that different choices are often accompanied by semantic differences of one sort or another. These differences are more on the order of 'focusing'—to be as vague as possible—than anything else, and do not seem to require positing 'subjects' and 'objects' in the deep structure. The 'focusing' difference may be extremely slight, as in the pairs i-ii and iii-iv, or it may have somewhat more 'cognitive content' as in the pairs v-vi and vii-viii.

- i. Mary has the children with her.
 ii. The children are with Mary.
 iii. He blamed the accident on John.
 iv. He blamed John for the accident.
 v. Bees are swarming in the garden.
 vi. The garden is swarming with bees.
 vii. He sprayed paint on the wall.
 viii. He sprayed the wall with paint.

Sentence vi seems to suggest, while v does not, that the whole garden has bees in it everywhere; and viii suggests, while vii does not, that the entire wall got covered with paint.

To the extent that other grammars make use of derived subjects and derived objects—which is the only alternative, within subject/object grammars, to treating verbs like *spray*, *blame*, *open*, *break* as involving elaborate and unexplained examples of homonymy—the semantic difficulties are just as great for them as they are for case grammar. Since the 'semantic effect' of the transformations in question is so different in kind from the semantic role of the case relations themselves, and since the latter are not affected by these processes, I am inclined to tolerate the reintroduction into

Subjectivalization, where it occurs, results in a neutralization of underlying case distinctions to a single form, usually called the 'nominative'. Objectivalization, where it occurs, neutralizes case distinctions to a single form which, where it is distinct from the form assigned to subjects, is traditionally termed 'accusative'. A third process which has the effect of effacing deep-structure case distinctions is the formation of nominals from sentences. The case modifications under nominalization transformations usually involve what is called the 'genitive'.

The brief mention above of situations in which there was an S embedded to the case category O suggested the ways in which case grammar must deal with verb and adjective complementation. A second source of embedded sentences is within the NP itself. The rule for NP may be stated as 97.

97. NP → N (S)

Where the N is an ordinary lexical item and the adjunct S contains a co-referential copy of the same N, the result is an NP consisting of a noun modified by a relative clause. One of the most obvious sources of 'genitive' is from relative clauses built on sentences which, by themselves, would have assumed the form *X has Y*. The N in the modified NP is the same as the N contained in the D of the adjunct sentence, and the V is empty. Thus, from 98 we get 99 by deleting the repeated noun, the tense, and the 'empty' verb and reattaching the D to the dominating NP.

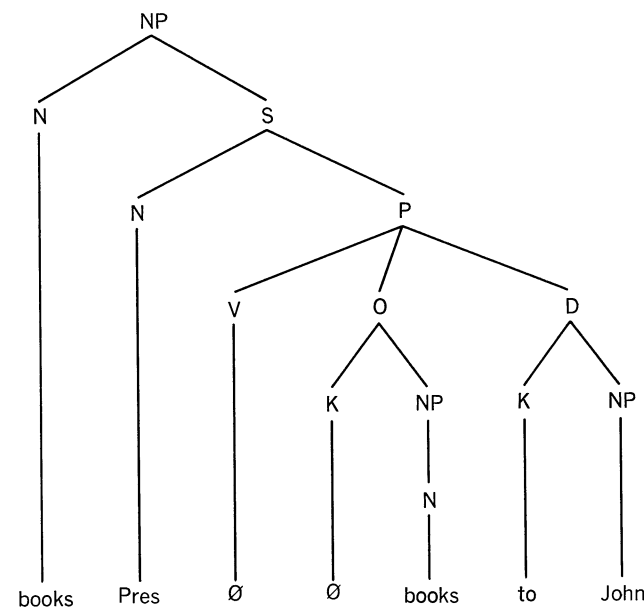

grammatical theory of transformations which have semantic import (of this highly restricted kind).

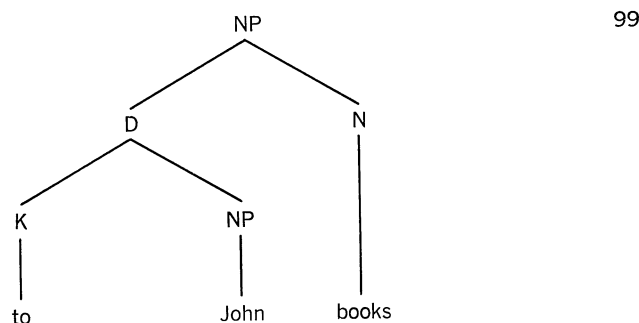

A D subjoined to an NP has its case marker modified—in this case to the sibilant suffix. Note 100.

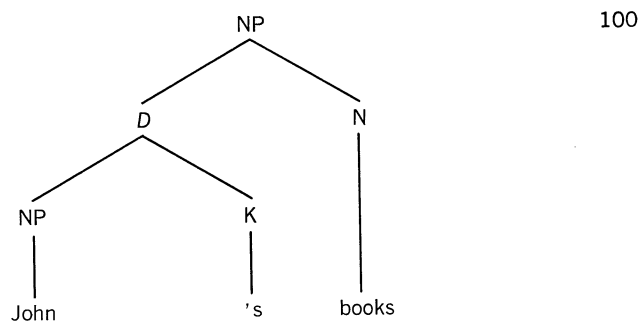

The 'true possessive' construction—resulting either in an NP of the form *X's Y* or *Y of X* in English—has as its source a sentence which by itself would have the form *X has Y*. The fact that in some languages there are instances of adnominal D not modified to the 'genitive' (*dem Vater sein Haus*, 'dative of possession') supports the view that conversion to genitive is a matter of the surface structure.

The interpretation of deverbal nouns which seems most satisfactory to me is that, except for the purely productive cases, the derivation of a noun from a verb is a matter of historical, not synchronic, fact. The synchronic reality is expressed by indicating that a given noun has a particular kind of relationship to a specific verb (or set of verbs), and that some of these nouns may, others must, appear in the NP frame [— S].

That is, instead of having a synchronic process for producing such words as Latin *amor* from its associated verb, what is needed is the classification of such a word as an abstract noun having a particular kind of relationship with the verb *amo*.⁵⁰ Nouns having this kind of special

⁵⁰ This treatment allows for the inclusion of nouns which lack etymological connections with their related verbs. We might wish to indicate for *book* a connection of the in-

relationship to specific verbs can take part in a process which introduces into the NP elements which 'originally' depended on the associated verb. The processes in question frequently have the effect of converting the form of the subsidiary NP's to the genitive.⁵¹ Thus the noun *amor* when qualified by a sentence of the form *deus amat . . .* yields *amor dei*; when it is qualified by a sentence of the form *deum amat . . .* the result is again *amor dei*. The D and O forms, in other words, are equally reduced to the genitive, and when only one noun is involved, potential ambiguities result.⁵²

4. Some Remarks on Language Typology

The view of universal grammar which is emerging is something like this: In their deep structure, the propositional nucleus of sentences in all languages consists of a V and one or more NP's, each having a separate case relationship to the P (and hence to the V). The most straightforward

tended kind with the verb *write*, thus accounting for the ambiguity of *your book* between 'the book which you own' (ordinary relative clause modification) and 'the book which you wrote'.

⁵¹ Exactly what universal constraints there are, if any, on the element to be converted to genitive is not at all clear. It appears that if there is only one element that shows up in the NP, it frequently takes the genitive form. Compare the ambiguous Sentence i with Sentences ii and iii.

- i. My instructions were impossible to carry out
 - (a) so I quit.
 - (b) so he quit.
- ii. My instructions to you are to go there.
- iii. * My your instructions are to go there.

In English it appears that if the conditions which allow the formation of the *of* genitive and the *s* genitive are satisfied by two different NP's in the associated sentence, multiple genitive constructions become possible, as in the following example borrowed from Jespersen.

- iv. Gainsborough's portrait of the duchess of Devonshire.

Japanese allows conversion to genitive in true relative clauses, as well as in the reduced relative clauses. A paraphrase of *v* is *vi*; *no* is the postposition most closely associated with functions which we would call 'genitive'.

- v. *Boku ga yonda zasshi*. 'I + subject + read - past + magazine'
'the magazines I read'
- vi. *Boku no yonda zasshi*.

⁵² Jespersen's suggestion that the ambiguity of *amor dei* is in the verb rather than the noun—the noun unambiguously identifying the subject, the verb being ambiguously either active or passive—must be understood as the hypothesis that only those NP constituents which are capable of conversion to surface subjects (with a given verb) may appear under genitive modification as modifiers of the deverbal noun. For English this may well be true. (Jespersen, 1924, p. 170.)

deep-structure commonalities between languages are to be sought at this 'deepest' level.

The lexical insertion rule for verbs is sensitive to the particular array of cases in the P. Since no distinction is needed between 'strict sub-categorization features' and at least the highest level of 'selectional features' (because redundancy relations exist between cases and some lexical features, and because there is no 'subject' outside of a 'VP' whose features need to be dealt with separately), the lexical insertion rule for verbs can be a strictly local transformation which responds to nothing more than the cases which are co-constituents of V (with the exception, as noted above, that it must be known whether the O element is an NP or an S).

The criteria for typological classification that have suggested themselves so far in this study are these:

- I. the presence or absence of modifications on the NP's as determined by the deep-case categories
 - A. the nature of such modification (prepositional, affixal, or other)
 - B. the conditions for the choice of particular case forms (which, when stated in their simplest form, constitute what is usually formulated as the 'case system' of the language)
- II. the presence or absence of concordial modifications of the verb
 - A. the nature of the concord (number agreement, incorporation of 'traces' of case categories, feature changes on V)
 - B. the relation to subject selection (topicalization)
- III. the nature of anaphoric processes
 - A. type of process (replacement by pro form, deletion, de-stressing, replacement by unstressed variants, or other)
 - B. conditions of application
- IV. topicalization processes (where 'subject selection' may be thought of as a special case of topicalization)
 - A. formal processes (fronting, modifying the case form, or other)
 - B. the variety of topicalization processes in the same language
- V. word order possibilities
 - A. factors determining 'neutral' word order (nature of case categories, 'ranking' of noun classes, topic selection, or other)
 - B. conditions determining or constraining stylistic variations on word order

It is important to realize that all of these typological criteria are based on superficial processes, and that there are no particularly good reasons for believing a priori that there will be much coincidence in the ways in which the different criteria sort out the world's languages.

4.1 The Bases for Determining Case Forms

The forms of the NP's in a P are determined on the basis of a variety of factors, one of which is the case category of the NP. Thus an NP under an I (that is, an instrumental noun) is assigned a particular form depending in whole or in part on the fact that it is under I.

Surface case forms of NP's are most elaborately developed in the personal pronouns. The study of the 'case' aspects of pronoun systems reveals a great deal about the variety of relationships that can hold between deep and surface cases.

Sapir's typological distinctions for Amerindian pronominal systems (1917b) can be expressed in case grammar terms quite simply. If we ignore whatever complications may exist in 'passive' constructions, and if we ignore all deep-structure cases except A and O, we can imagine sentences of the following three types given in their underlying propositional form:

- | | |
|---------------|---|
| (a) V + A | intransitive sentences with active 'subjects' |
| (b) V + O + A | transitive sentences with agents |
| (c) V + O | intransitive sentences with inactive 'subjects' |

Since the V element is constant to the formulas, we can represent these three sentence types by presenting the case frames in three lines, as follows:

	A
101	O A
	O

According to Sapir, then, there are languages which, like Yana, have only one form for pronouns in all four of these positions.

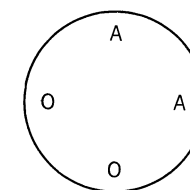

102

There are languages like Paiute that have a separate form for the O element in the transitive sentence, all others being the same. The two forms are traditionally called 'nominative' and 'accusative'.

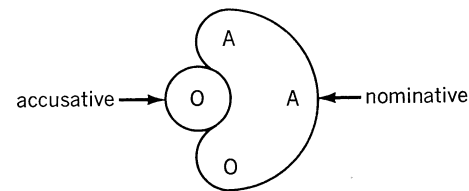

103

There are languages like Chinook which give one form to the A of transitive sentences and another to the remaining cases. The terms 'ergative' and 'nominative' are often given to a distinction made in this way.

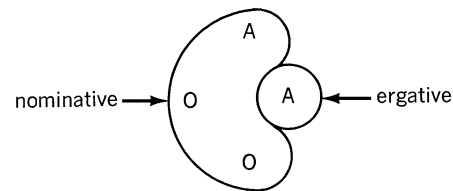

104

There are languages like Dakota which have separate forms for A and O; here the terms are usually 'active' and 'inactive'.

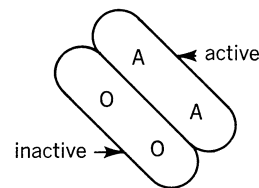

105

And, lastly, there is the situation found in Takelma, which has one form for the pronominal NP of intransitive sentences, and two separate forms for the A and O of transitive sentences. Thus:

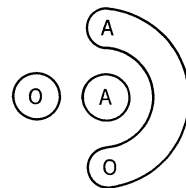

106

What these observations are intended to suggest is merely that if I correctly understand Sapir's analysis of the pronominal systems of these languages, then the case concepts I have been discussing, together with the notion of clause types which various arrays of them define, provide

the categorial and configurational information for determining the surface distinctions that are found in these languages.

4.2 Verbal Concord

There are these various ways, and possibly more, in which cases and case environments are involved in determining the case forms of NP's within a P. An additional factor is whether the given NP has been chosen as subject in languages having subjectivalization processes. Choosing subjects or topics is related to another aspect of the superficial structure of sentences, and that is verbal concord.

The choice of subject in English always has the effect of determining number concord (on those verbal and auxiliary elements capable of reflecting number concord). Apart from number concord, the choice of subject might involve modification of the verb to its passive form, or introduction of the verb *have*.

The information 'registered' in the V may have only to do with the choice of subject, as in English, or it may be more elaborate. Languages which 'incorporate' pronominal affixes into the V may do so for more than one NP at a time; or noun stems themselves from particular cases may be incorporated into the verbal expression.⁵³

The subject selection rules discussed for English may be compared with the topicalization processes that are described for Philippine languages. The situation for Maranao has recently been described by McKaughan. One NP is chosen as topic for every sentence, and this choice is recorded in the following way: its original case preposition is replaced by *so*, and an affix is inserted into the V which indicates the case category of the chosen NP. There is apparently considerable freedom in the choice of topic. To take the verb meaning 'to butcher' (*/sombali?/*), we find that when the topic noun is an original I, the verb takes on the prefix */i-/*, as shown in 108; and when the topic is an original B, the suffix */-an/* is added to the V, as seen in 109.

107. *somombali? so mama? sa karabao*

'The man butchers the carabao.'

108. *isombali? o mama? so gelat ko karabao*

'It is with the knife that the man butchers the carabao.'

109. *sombali?an o mama? so major sa karabao*

'It is for the mayor that the man butchers the carabao.'⁵⁴

⁵³ Grammatical devices for providing concord of this type have been worked out for Mohawk by Paul M. Postal (see Postal, 1963).

⁵⁴ McKaughan (1962). The examples and the description of the relationships are from McKaughan, but a great deal of guessing lies behind my interpretation.

The choice of sentence subjects, or 'topics', from particular cases appears to be the most satisfactory way of accounting for the many types of voice modifications of verbs such as those described as middle, pseudo-reflexive, and so forth, in the Indo-European languages.

4.3 Anaphoric Processes

Anaphoric processes are best understood from the point of view of an extended concept of sentence conjunction. That is, every language has ways of simplifying sentences connected by conjunctions or subjunctions, and the processes used under these conditions seem to be exactly the same as those used in sentences connected in discourse. The grammarian's job, therefore, is to describe these processes as they work in sentences that are independently intelligible, and then to assume that utterances in connected texts or conversations can best be understood from the point of view of a shared knowledge of the language's anaphoric processes on the part of speaker and hearer.⁵⁵ The fact that in these anaphoric or reduced forms English uses pro-replacement under conditions that would call for deletion in some other language may thus be seen as a superficial difference between the two languages.

The point is important—and it was mentioned above in connection with 'bad' reasons for rejecting the universality of the subject/predicate division—because the absence of subjects in the final surface forms of sentences in some languages is seen by many scholars as having great typological relevance. The optional absence of NP constituents in languages with person-marker incorporation (for example, Chinook) has led scholars to claim that such languages lack the nexus relations that Europeans understand as 'subject' and 'object' but have instead what are described as 'appositional' relations between NP's and V's (see Sommerfelt, 1937). In languages without pronominal incorporation, a distinction is made by some scholars between true subject/predicate languages and those in which the so-called 'subject' is as much a 'complement' to

⁵⁵ In other words, the grammarian will describe the process by which *i* is converted to *ii* by noting the conditions under which repeated elements in conjoined sentences may undergo deletion and pro-replacement and under which conjoined sentences can have words like *too* and *either* added to them.

- i. Mary didn't want any candy and Mary didn't take any candy.
- ii. Mary didn't want any candy and she didn't take any either.

In contexts in which the information contained in the first conjunct of *i* is already understood by the addressee (by having just been spoken by him, for example), a speaker of English feels free to use the reduced form in *iii*.

- iii. She didn't take any, either.

There is no reason, it seems to me, to expect the grammar of a language to generate sentences like *iii* directly.

the V as is the direct object or any of the various adverbial elements. To Martinet, a subject is different from a complement only if it is 'constitutive of the minimal utterance' (1962a, pp. 61–62)—that is, only if it is obligatorily present in both full and anaphorically reduced utterances. In Japanese, the 'minimal utterance' lacks a subject, and hence, the argument goes, Japanese sentences lack the subject/predicate structure of sentences in our more familiar languages. To Martinet's disciple Saint-Jacques, this typological 'fact' about Japanese is regarded as excessively important. It is only by dint of considerable intellectual effort that the Westerner can achieve that liberation from familiar ways of thinking about language which is required for an understanding of the true character of Japanese. Or so Saint-Jacques tells us (1966, p. 36). It seems to me that language typology offers enough genuine excitements to make it possible for us to give this one up. The intellectual achievement of which M. Saint-Jacques speaks is that of knowing that when there is an 'understood' NP to deal with, some people replace it by a pronoun, others get rid of it.

4.4 Topicalization

The fourth criterion has to do with topicalization processes, devices for isolating one constituent of a sentence as 'topic', of bringing one particular constituent of a sentence into some kind of 'focus'. Where topicalization is distinct from processes for 'emphasizing' a constituent, we have much the same thing as what I have been calling 'subjectivalization', but which I shall now begin calling 'primary topicalization'. Primary topicalization for English involves position and number concord; stylistic changes involving stress assignment, late word-order changes, and possibly the 'cleft-sentence construction' fall into what might be called 'secondary topicalization'. From what I understand of McKaughan's account (1962, p. 47), primary topicalization in Maranao involves replacement of the original preposition associated with a noun by *so* and introduction into the V of an associated case indicator, while secondary topicalization involves moving an NP to which *so* has been added to the front of the sentence. One might refer to Oertel's study of the disjunct use of cases in Brāhmaṇic prose as a study of secondary topicalization.⁵⁶ I would imagine that all languages possess some means of carrying out

⁵⁶ 1936. Oertel distinguishes 'pendent' uses of a disjunct case, where the 'topic' is in the 'nominative' even if its original role in the sentence was not that of subject (comparable, I assume, to *he* in 'he, I like him'), and 'proleptic' uses, where the topic retains the original case form, is moved to the front of the sentence, and may or may not be resumed (in the form of a demonstrative) in the remainder of the sentence (comparable to *him* in *him, I like (him)*).

'secondary topicalization', but it may be the case that some lack the process of 'primary topicalization' (subjectivalization).⁵⁷

The notion 'subjectivalization' is useful only if there are sentences in a language which offer a choice of subject. Languages described as not having passives, or languages described as only capable of expressing transitive sentences passively, apparently lack the grammatical process of primary topicalization.

This question leads naturally to the problem of the so-called 'ergative' languages. Recall that in the accusative type of pronominal system, the pattern was

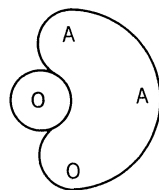

and that in the ergative type it was

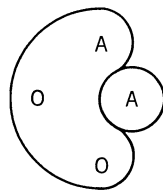

Now when languages of the accusative type have passive versions of sentences whose propositional form is [V O A], the case forms associated with the elements in the passive version are generally 'nominative' for the O and 'agentive' (realized as ablative, instrumental, or what have you, depending on the language) for the A. If passive sentences were introduced into our three-line diagrams and their active counterparts removed, we would get the pattern

⁵⁷ Jeffrey Gruber's recent study (1967) of topicalization in child language suggests that ontogenetically motivated (what I am calling 'secondary') topicalization precedes the use of formal subjects in English. It may be that when one device for topicalization becomes 'habitual', it freezes into a formal requirement and the language must then call on other processes for motivated topicalization.

Kenneth Hale (correspondence, 1967) reports that for Walbiri, an 'ergative' language of aboriginal Australia, there is apparently no 'subjectivalization' process, but any constituent may be repeated to the right of the proposition, the element inside the proposition being replaced by a pro form.

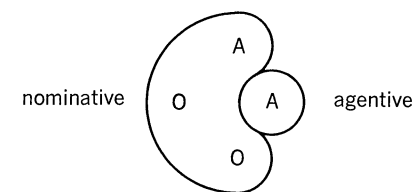

which is exactly like that for the regular assignment of cases in the ergative languages. This fact, plus the use of the term 'nominative' for subject-of-intransitive-*cum*-object-of-transitive in these languages, has led many scholars to identify the ergative case in ergative languages with the agentive case form found in passive sentences in accusative languages, and to conclude that the ergative languages are really 'passive' languages—languages in which transitive sentences can only be expressed passively.⁵⁸ For both of these systems, the case that has been given the name 'nominative' is frequently described as the 'subject' in a subject/predicate construction, and the 'ergative' element in the one instance and the 'accusative' element in the other are treated as verbal complements (see Trubetzkoy, 1939). The difficulty of determining the 'subject' in ergative languages has been described by Martinet (1962b, pp. 78 f.): Some scholars identify as subject the word which would be the subject in a translation of the sentence into French—that is, the nominative in intransitive sentences and the ergative in transitive sentences. Others regard the nominative as the subject in all sentences, thus giving transitive sentences a 'passive' interpretation. Lafon gives up on transitive sentences—he uses the term 'subject' only for intransitive sentences, saying of transitive sentences that they have no subject.

Vaillant, on the other hand, spoke of the northern Caucasian languages as having three types of verbs: (a) true intransitives, with subjects in the 'nominative'; (b) 'operative pseudotransitives', with 'pseudosubject' in the 'ergative'; and (c) 'affective pseudotransitives', with 'pseudosubjects' in the 'dative' (1936, p. 93). It seems quite clear that what he is dealing with are sentences having P's of the three types—[V O], [V O A], and [V O D]—where the surface cases for O, A, and D are 'nominative', 'ergative', and 'dative', respectively. It looks very much as if that is all there is to say. For my part I would much rather say of the ergative languages that they lack subjectivalization, than say either that all transitive sentences undergo obligatory passivization, or that some of their sentences contain true subjects while others do not.

⁵⁸ Note that even if there is a different form for the verb in [____ O] and [____ O + A] case frames, this cannot be interpreted as evidence of 'passivity'. As mentioned earlier, in languages not of the ergative type there may still be systematic variation of the same verb root depending on whether it is used transitively or intransitively.

The frequent claim that the ergative languages are more primitive than the accusative languages are (see Tesnière, 1959, p. 112), together with the assumption that the ergative construction is really a passive construction, has led such scholars as Kuryłowicz, Schuchardt, and Uhlenbeck to assume that the passive construction represents a more primitive concept in the evolution of language than that of the active transitive construction. Evidence mustered for this position includes the signs that pre-Indo-European was of the ergative type, and the fact that some languages have 'invented' *have*-like verbs in relatively recent times. The invention of *have* made it possible to give active expression to certain tense or aspectual forms which had remained unaffected by the general change from passive to active expression (as is seen, for example, in the circa third century shift from expressions of the type *inimicus mihi occisus est* and *mihi illud factum est* to transitive expressions using *habeo*: *inimicum occisum habeo* and *habeo illud factum* (see van Ginneken, 1939, p. 86)).

It seems very unlikely to me that syntactic changes of the type known from the present state of our knowledge are really capable of showing an intellectual evolution of a type as potentially significant as whatever might be understood as the transition from an essentially passive to an essentially active point of view. The connection claimed by van Ginneken between ergativity and the 'feminine' character of cultures with ergative languages is another that should be questioned.⁵⁹

4.5 Word-Order Differences

The fifth criterion suggested for a language typology is that of word order. The variables that determine or constrain the freedom of word order in the languages of the world are very likely to have many important connections with the case structure of sentences; but this is an area which I have not examined at all.

⁵⁹ The following seems worth quoting in full (1939, pp. 91 f):

Nous sommes tous des hommes, et tous nous avons deux talents: les facultés plus actives de l'appétit et de la volonté, et les facultés plus passives des sensations et de l'appréhension; mais il est évident que les deux sexes de l'humanité montrent sous ce rapport une différence sensible.

L'ethnologie moderne, qui a écarté définitivement comme insuffisante la doctrine du développement uniforme, nous apprend cependant que le progrès de l'humanité a balancé presque toujours entre les cultures plus féminines ou plus masculines, dites cultures matriarcales et patriarcales. Ce sont toujours les cultures matriarcales très prononcées qui, comme le basque, ont un verbe transitif de nature passive avec comme casus rectus un patiens et comme casus obliquus un agens; mais les cultures patriarcales, comme l'indoeuropéenne ont un verbe transitif de nature active, animiste et magique, avec un sujet au casus rectus et un objet au casus obliquus. Chaque peuple a donc le verbe qu'il mérite.

5. The Grammar of Inalienable Possession

The preceding sections have contained an informal description of a syntactic model for language and a few demonstrations of the operations of this model of the sort that has come to be called 'restatement linguistics'. In the present section I shall attempt to show how a particular substantive modification of the rules will permit a uniform way of describing the interesting collection of grammatical facts associated with what is called 'inalienable possession'.

Every language, one can be sure, has nouns which express concepts that are inherently relational. Examples of inherently relational nouns in English are *side*, *daughter*, and *face*. One doesn't speak of a side, but of a side of something; one doesn't say of someone that she is a daughter, only that she is somebody's daughter; and although it is possible to speak of having seen a face, the word is typically used when referring to 'his face' or 'your face' or the like. The relational nouns most frequently discussed in the linguistic literature are names of body parts and names of kinsmen. My discussion here will concentrate on body parts.

5.1 The Data

5.1.1 Significant syntactic relationships exist between the dative and the genitive cases in all of the Indo-European languages; and in all but Armenian, according to Havers (1911, p. 317), the dative and the genitive case forms figure in paraphrase relationships of kinds that are highly comparable from language to language. The relationship is observed only when the associated noun is of a particular type. To take some of the modern German examples given by Havers, we observe that a paraphrase relation exists between 111 and 112 as well as between 113 and 114; but that of the two sentences 115 and 116, the latter is ungrammatical (as a paraphrase of 115).

- 111. *Die Kugel durchbohrte dem Feind das Herz.*
- 112. *Die Kugel durchbohrte das Herz des Feindes.*
- 113. *Er hat mir die Hand verwundet.*
- 114. *Er hat meine Hand verwundet.*
- 115. *Der Vater baute seinem Sohn ein Haus.*
- 116. * *Der Vater baute ein Haus seines Sohnes.*

It should be noted that *Herz* and *Hand* are the names of body parts, while *Haus* is not.

5.1.2 There are cases like the above where a given language exhibits in itself the paraphrase relationship, and there are also cases where it

appears that one language has chosen the dative expression, another the genitive. Notice the following sentences, also from Havers (1911, p. 1).

117. My heart aches: *Mir blutet das Herz.*
 118. Tom's cheeks burned: *Tom brannten die Wangen.*
 119. She fell on her mother's neck: *Sie fiel ihrer Mutter um den Hals.*

5.1.3 There are adnominal (possessive) uses of dative constructions, particularly, it appears, when the possessive pronoun is also used with the possessed element. Here the most readily available examples are with kinship terms (Havers, 1911, p. 283).

120. *Dem Kerl seine Mutter.*
 121. *Sa mère à lui.*

5.1.4 Many languages have separate possessive affixes for nouns that are obligatorily possessed (inalienables) and nouns that are optionally possessed (alienables). The difference in Fijian is apparently expressed by preposing the possessive morpheme to indicate alienable possession and suffixing it to indicate inalienable possession. Since the category 'inalienable' is a category of grammar rather than a property of real world objects (since, in other words, some objects grammatically classed as inalienable can in fact be separated from their 'owners'), the distinction can be seen most clearly if both methods of expression can be used with the same noun stem. Lévy-Bruhl gives a persuasive example of this situation (1916, p. 99): Fijian *uluqu* means the head which is now firmly attached to my neck, while *kequ ulu*, also translatable as 'my head', would refer to the head which, say, I am about to eat.

Languages may have separate morphemes for indicating alienable and inalienable possession, and they may have further distinctions among these morphemes depending on the type of inalienable possession (as Nootka, for example, suffixes *-pat-* to nouns representing physically inseparable entities, for example, body parts, but uses other means for kinship terms), or they may merely have a class of nouns incapable of occurring as free forms—noun stems requiring affixation of possession indicators.⁶⁰

In all of these cases, it appears, the features in question are 'grammatical' rather than purely 'notional'. Discussions of inalienable possession almost always contain lists of nouns whose grammatical classifica-

⁶⁰ This last situation is sometimes described by saying that nouns are 'inflected for person' (see Manessy, 1964, p. 468).

The full variety of the treatment of inalienable possession in different Amerindian languages is catalogued in Sapir (1917a).

tion is the opposite of what one would notionally expect. Lévy-Bruhl (1916, p. 96) mentions a case where the word for 'left hand' functions as a body-part word grammatically, but the word for 'hand' does not. And Arapaho classifies 'louse' (or 'flea') among the inalienables (Salzmann, 1965, p. 139), a situation that invites people who like to speculate on these things to propose something or other on the Arapaho conception of 'self'.

5.1.5 Milka Ivić has recently discussed many instances of what she calls 'non-omissible determiners' (1962, 1964). Among the examples she cites are many that involve nouns of the type frequently included among the inalienables. The adjective cannot be deleted, for example, in the Serbo-Croatian expression in 122, for 123 is ungrammatical (1964, p. 477).

122. *devojka crnih očiju*, 'the girl with black eyes'
 123. * *devojka očiju*

What is misleading about her discussion, it seems to me, is the decision to associate with the adjective the 'category of nonomissibility'. It is as if we wished to say, for the English Sentence 124, that there is something grammatically significant about the word *missing*, since its deletion results in Sentence 125 which is somewhat different in type from the original; put differently, Sentence 124 does not say the same thing that 126 does. What is genuinely important about 124 is its paraphrasability as 127 (or 128) and the fact that the construction exhibited by 124 is restricted to certain kinds of nouns. Note the ungrammaticality of 129.

124. I have a missing tooth.
 125. I have a tooth.
 126. I have a tooth and it is missing.
 127. My tooth is missing.
 128. One of my teeth is missing.
 129. * I have a missing five-dollar bill.

5.1.6 Note that in Sentences 124 and 127, three things are involved: (a) a possessor (an 'interested person', to use the traditional term), (b) a body part, and (c) an attribute—(a) *me*, (b) *tooth*, and (c) *missing* respectively—and that the sentences provide alternate ways of ascribing the attribute to the possessor's body part. They are two distinct superficial ways of expressing the same relationship among these three concepts.

Using P, B, and A for *a*, *b*, and *c* above, we may represent the expression as seen in 124 as 130, and that as seen in 127 as 131.

130. P^{nom} *have* [A → B^{acc}]
 131. [P^{gen} → B] *be* A

The same element, in other words, which in some of the paraphrases mentioned above appeared in either the dative or the genitive case forms now appears as the subject of the verb *have*. Bally, in fact, speaks of the invention of the word *have* as fulfilling precisely the function of allowing the *personne intéressée*, which otherwise would have to appear either in dative or genitive form, to become the subject of a sentence. Examples of all three surface appearances of a first person possessor are given by Bally (1926, p. 75) as 132–134. Sentences 133 and 134 correspond to expression types 130 and 131 respectively; the expression type exemplified by 132 is given as 135.

132. *Mihi sunt capilli nigri.*
 133. *J'ai les cheveux noirs.*
 134. *Mes cheveux sont noirs.*
 135. P^{dat} [B^{nom} *be* A]

5.1.7 Henri Frei surveyed this variety of surface representations of the 'same' sentences and added a fourth type, a type intermediate, in a sense, between that suggested by Formula 135 and that of 130. His example was Sentence 136 (it also provided the title of his paper), which exemplifies the expression type we may wish to represent as 137.

136. *Sylvie est jolie des yeux.*
 137. P^{nom} *be* [A B^{oblique}].

Frei points out that the construction seen in 136 is related to the category of inalienable possession, since while 138 and 139 are acceptable sentences, 140 and 141 are not.

138. *Elle est fine de doigts.*
 139. *Elle est bien faite des jambes.*
 140. * *Elle est fine d'étoffe.*
 141. * *Elle est bien faite des vêtements.*⁶¹

⁶¹ Frei (1939, p. 188). The expressions are limited to clear relational nouns, not only to body parts. Frei notes such phrases as 'des couloirs spacieux et *bas de plafond*' and 'libre de moeurs'. He beautifully demonstrates the distinctness of the sentences involving inalienable possession from overtly similar sentences of different grammatical structures with the contrast between i and ii below (p. 186).

- i. *La salle est pleine de visages.*
 ii. *La femme est pleine de visage.*

5.1.8 Since Frei sees this diversity as resulting from the attempt to 'condense' two judgments into one sentence—the two judgments that *P has B* and that *B is A* (in our terms)—he relates the constructions in question to the much discussed 'double subject' constructions of Japanese. In one type of this latter construction, two nouns appear before a verb or adjective, the first followed by the particle *wa* (indicating what I have called 'secondary topicalization'), the second by the particle *ga* (the particle of 'primary topicalization'). (Variations in the order and in the choice of particles do not change the status of the construction; the form described is the one most stylistically neutral.) The second of these nouns is of the inalienable type; the first identifies the object with respect to which the object identified by the second noun is 'inalienable'. The hackneyed example of the double subject construction is 142, a sentence which has 143 as a sort of forced paraphrase. In 143, the particle *no* is the particle whose functions are closest to those we would be inclined to label 'genitive'.

142. *Zoo wa hana ga nagai.* 'Elephant *wa* nose *ga* long.'
 143. *Zoo no hana ga nagai.*

5.1.9 That expressions involving entities viewed as being closely associated with an 'interested person' have unique grammatical properties has also been observed in certain semantically unmotivated uses of 'reflexive pronouns' and the parallels one finds between these and various uses of the 'middle voice'. The connection with dative forms is seen in the fact that in some languages a kind of 'dative reflexive' is used in these special situations. Note 144 and 145.

144. *Se laver les mains.*
 145. *Ich wasche mir die Hände.*

The connection between this use of the 'reflexive' and the category of inalienable possession is indicated by Bally, who points out that in item 146, *jambe* is the inalienable entity, while in 147 the word *jambe* can only (or, depending on my informants, can also) be understood as some independently possessed object, such as the leg of a table.

146. *Je me suis cassé la jambe.*
 147. *J'ai cassé ma jambe.*

Notice that the *jambe* which does *not* have the possessive adjective is the one which is grammatically characterized as 'obligatorily possessed' (Bally, 1936, p. 68)!

5.2 Adnominal Datives

One way of introducing a possessive modifier of a noun has already been suggested: a sentence which could on its own assume the form 'X has Y' is embedded to NP. Since it is desirable for an embedded sentence to have a semantic interpretation that contributes to the meaning of the whole sentence, the sentence-embedding source of possessives is needed as an explanation for alienable possession. In other words, one is satisfied to have the meaning of 148 represented as a part of the meaning of 149, though we may reject such a relationship between 150 and 151.

148. I have a dog.
 149. my dog
 150. I have a head.
 151. my head

A distinct method is required for introducing the possessive element in the case of inalienable possession, a method which reflects the fact that the relationship between the two nouns in 'inalienable possession' is not (*pace* Frei) a sentential relationship.

For the types of inalienable possession that we have considered so far—in which the relationship has always been to an animate or 'personal' entity—the solution is to say that some nouns obligatorily take D complements. This can be managed by adding to the grammar another way of writing NP, namely the rule in 152.

152. NP → N (D)

In the way that frame features for V's relate to environments of V's provided by the constituent P, frame features for N's relate to environments provided by the constituent NP. It was suggested above that N's which obligatorily take S complements are assigned the feature +[— S]. We may now add that N's which obligatorily take D complements are characterized as having the feature +[— D]; and these are the inalienably possessed nouns. The notation imposes a subclassification of nouns into those which require adnominal D (such as *son*, *child* in the meaning 'offspring', German *Mann* in the meaning 'husband') and those which reject adnominal D (such as *person*, *child* in the meaning 'very young person', *Mann* in the meaning 'man').

The two sources of possessive modifiers which the grammar now makes possible (adnominal D and adnominal S of a certain type) provide the deep-structure differences needed for determining the difference in the form of the possessive modifiers in those languages which make the

distinction overt in that way. Where further distinctions are made (as between body parts and kinship terms), the information on which such distinctions need to be based may be included as lexical features of the N's themselves.

The general configuration of NP's containing D's, then, is that shown in 153.

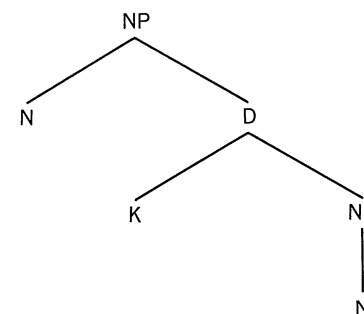

153

In some cases the adnominal D remains in the NP and in fact retains the surface features associated with D, as in 154; typically, however, a D inside an NP is changed to a genitive form, as in 155.

154. secretary to the president
 155. the president's secretary

If determiners are universal,⁶² then the expansion of NP must make provisions for them; but if they are not, then languages which have them will need 'segmentalization' rules of the type described by Postal (1966). At any rate, the determiners (which I represent as 'd') will figure in the various things that can happen to adnominal D. Sometimes, for example, when a D remains in the NP without undergoing genitive modification, certain of its features are copied onto the determiner so that the determiner may eventually assume the form of the appropriate 'possessive adjective'. This seems to account for such expressions as the possessive dative with kinship terms seen in some German dialects (recall 120) in Ossetic (see Abaev, 1964, p. 18).

5.3 Some Illustrations

The D constituent often need not remain in the NP: under some conditions it may be 'promoted', so to speak, from the status of a modifier of an N (which it is in the deep structure) to the status of a major

⁶² I am inclined to think that they are. See Fillmore (1967).

constituent on the next higher level of the syntactic structure. This can be seen in sentences having the base configuration [V + L + A]: just in case the N under L is a body part, the D which in the deep structure is subjoined to L is 'promoted' to become a constituent of P, yielding a sentence superficially of the type [V + D + L + A].

The verb *pinch* is accepted into the case frame [— L + A], and except when it has taken on the feature [+passive], it is a verb which deletes the preposition of the following constituent. Let us consider sentences derivable from the deep structure seen in 156.

156

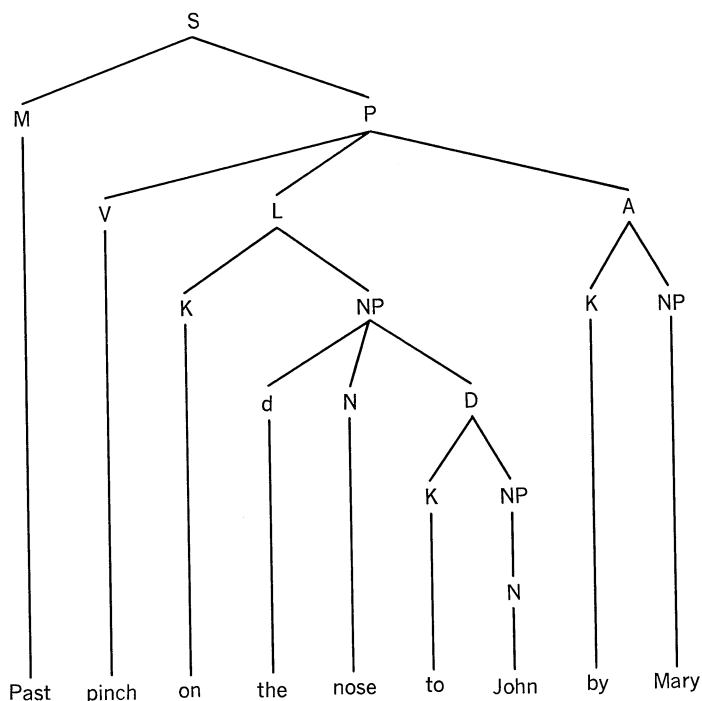

We shall see what happens to the sentence under four conditions: when the D remains inside L and A becomes the subject; when the D remains inside L and L becomes the subject; when the D is promoted and A becomes the subject; and when the D is promoted and D becomes the subject.

Whenever D remains inside NP (in this sentence), it is preposed to the N and converted to its genitive form, displacing the original determiner. Since it is a personal noun, the K element assumes the form of a genitive suffix. With nonpromoted D, in other words, 156 eventually becomes 157.

157

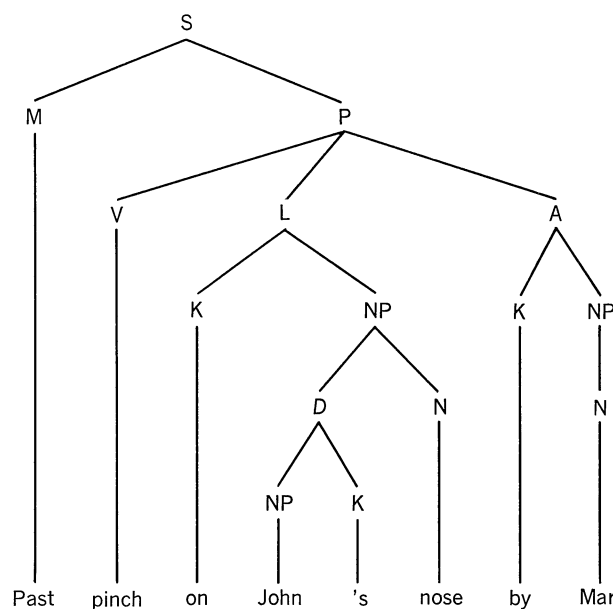

Diagrams 158–161 show the development from 157 when A is made the subject: the subject preposition is deleted and its case category is erased; the preposition after *pinch* is deleted and the case category L is erased; and the tense is absorbed into the V.

158

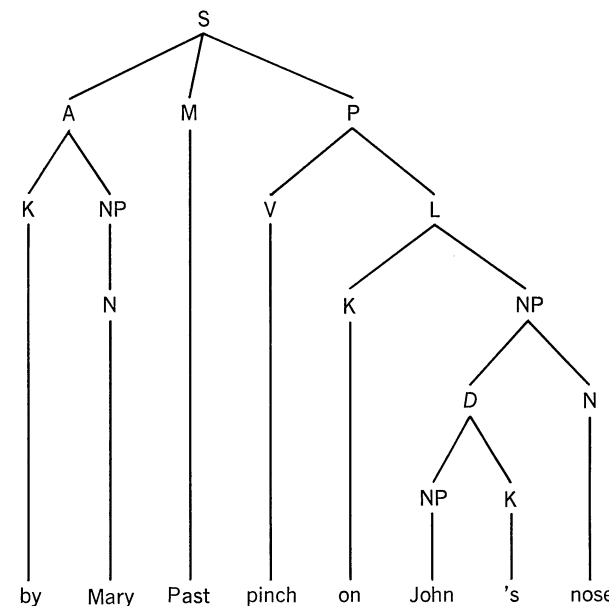

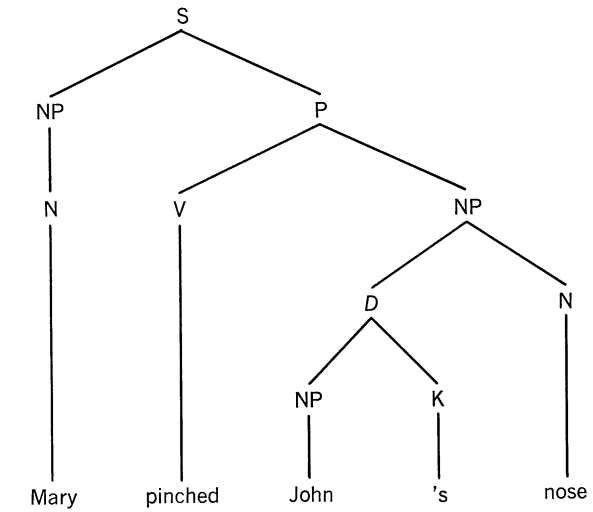
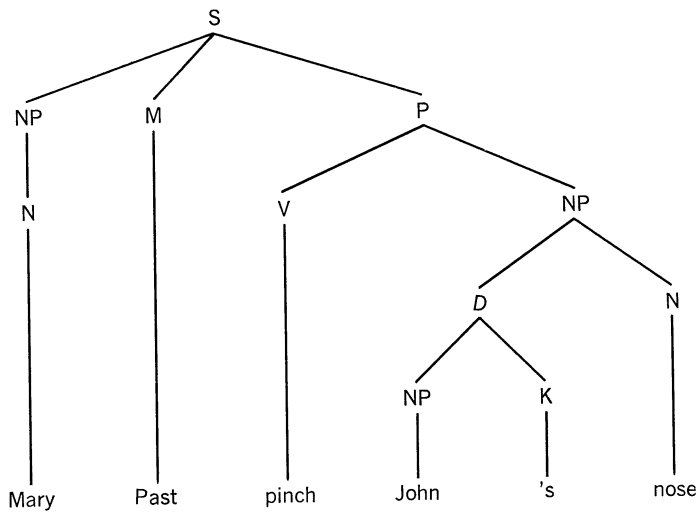
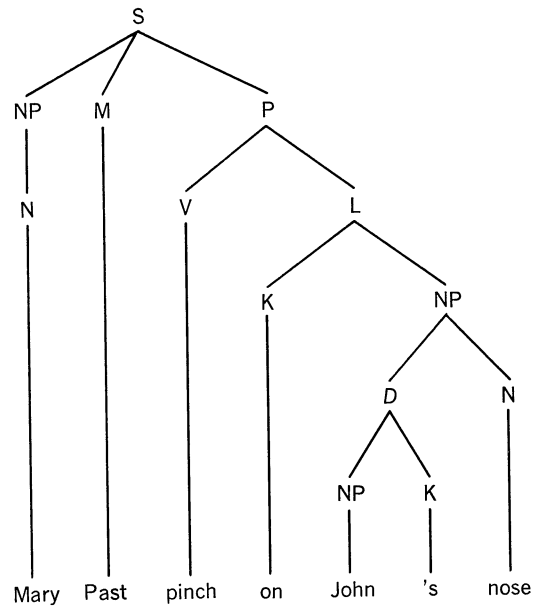

If the L of 157 is chosen as subject instead of the A, the result is 162. This choice of subject requires the V to assume the feature [+passive], which causes it to lose its ability to delete following prepositions and its ability to take tense affixes. The surface structure eventually resulting from 162 is 163.

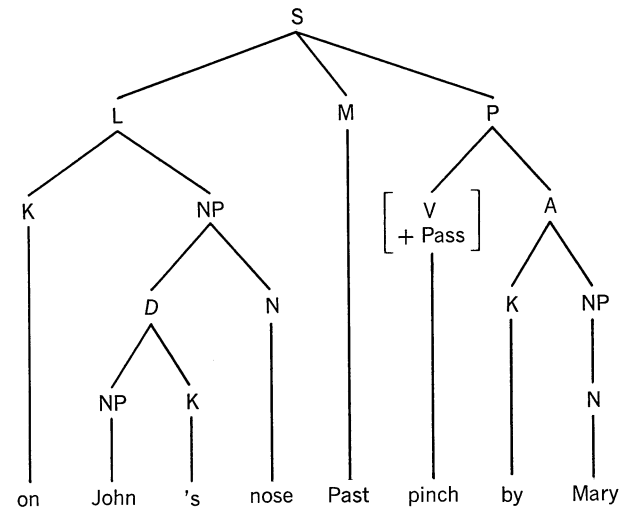

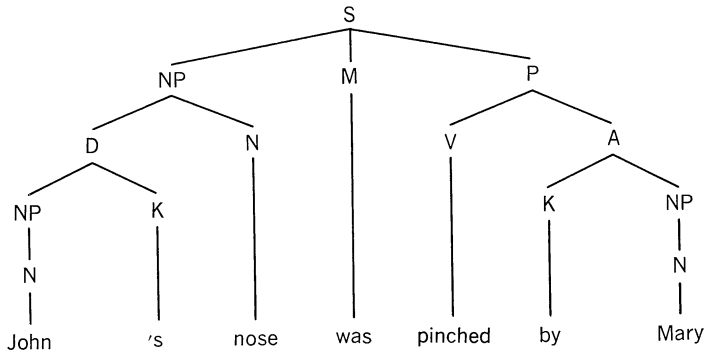

Backing up to 156, we may now see the consequences of 'promoting' adnominal D. When the D is removed from L and becomes the left-most case constituent in P, the resulting structure is 164.

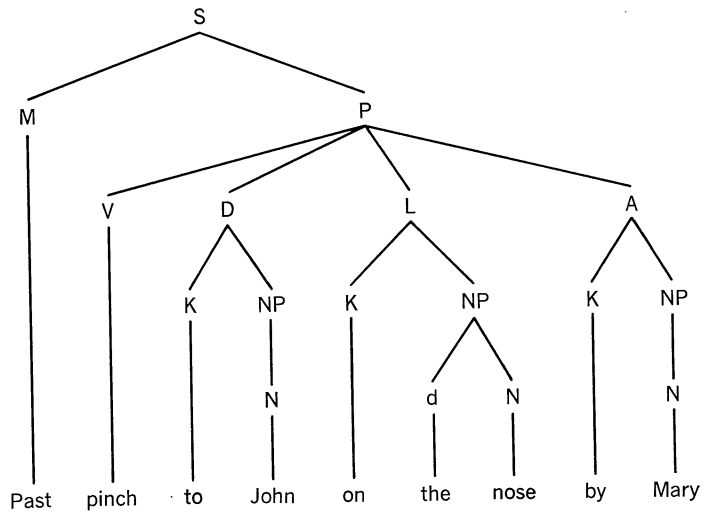

The possible subjects for 164 are the A or the newly promoted D. When the subject is A, we get 165, a structure which, on application of the rules we have learned, eventually becomes 166.

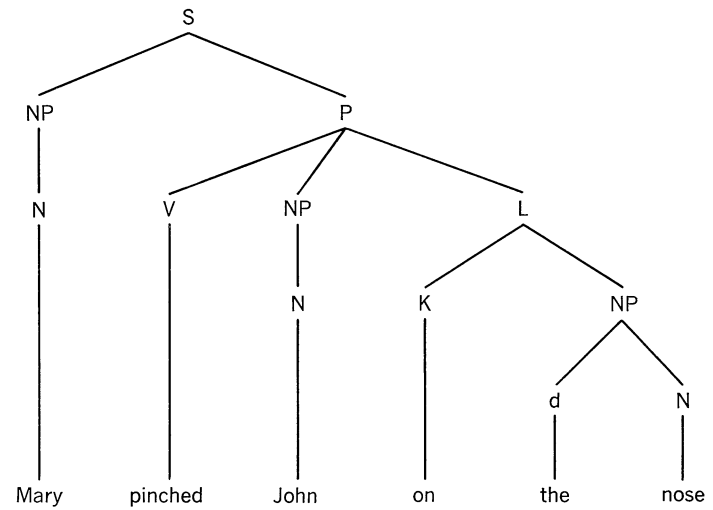
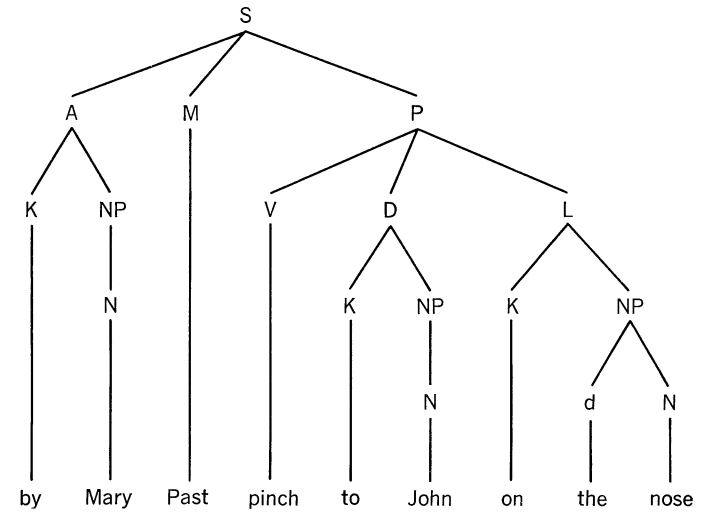

When D is made subject, on the other hand, we get 167; on applying the rules appropriate to a V with the feature [+passive], we eventually get 168.

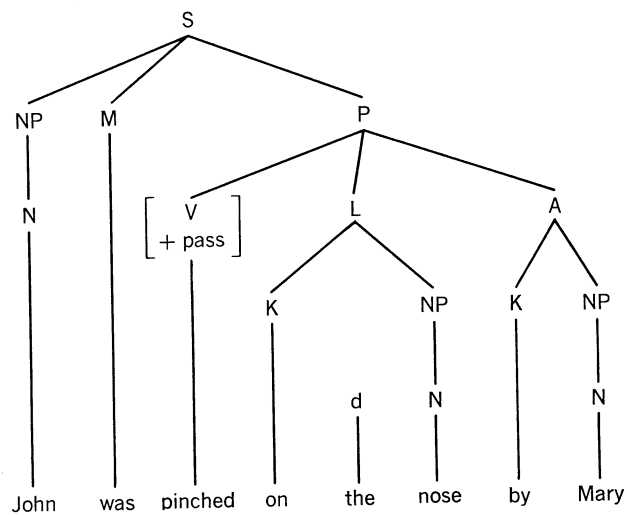
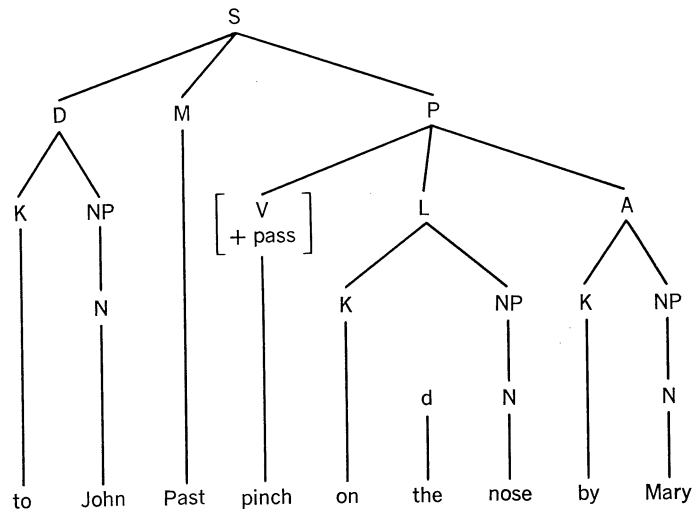

168

We may turn to the problem which interested Bally and Frei and examine the role of adnominal D in sentences which assign attributes to obligatorily possessed elements. The basic structure of such sentences can be illustrated by 169.

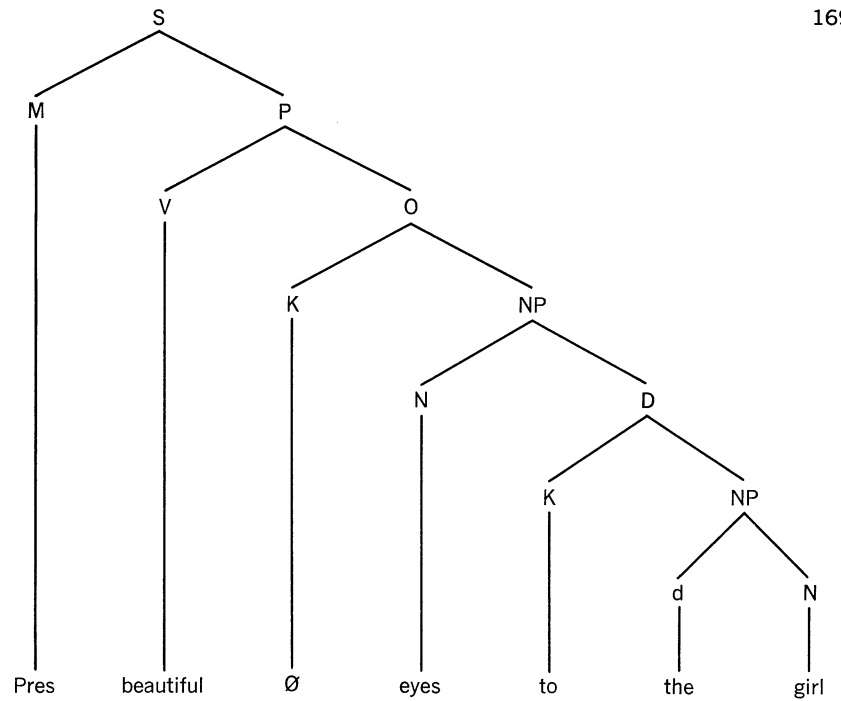

169

In languages which allow the D to remain in the NP, the D element is converted to its genitive form. In English this results in 170. Since 170 has only the form [V + O], the O is necessarily chosen as subject, and the result for English is 171.

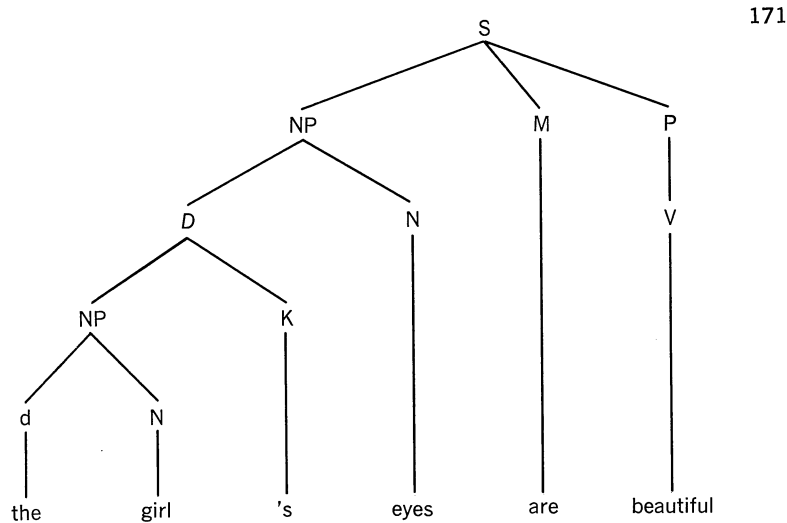
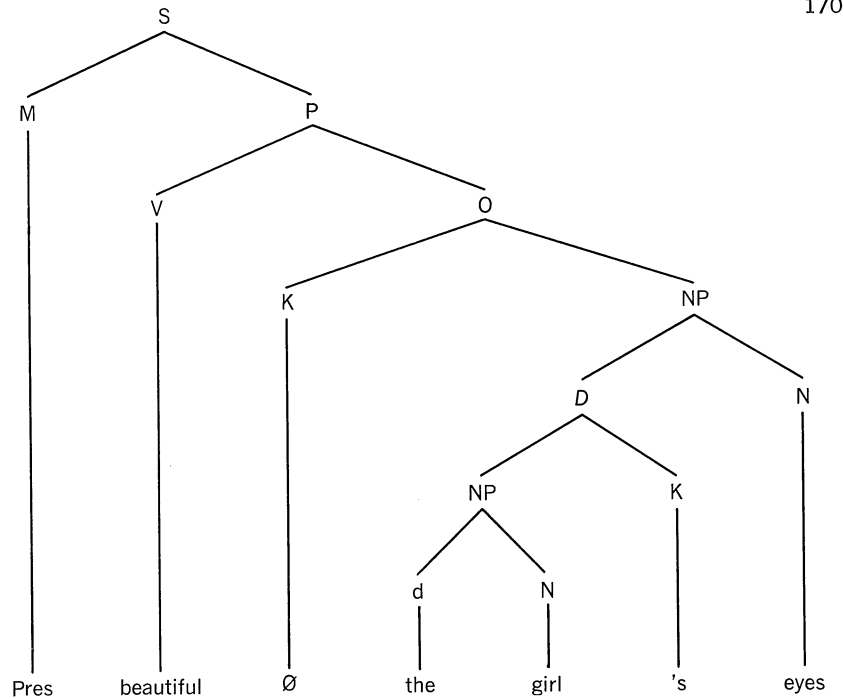

Notice that since the V is an adjective, it is incapable of 'absorbing' the tense,⁶³ so that it requires the provision of *be* within the M constituent.

⁶³ Stated more accurately, V's which are adjectives, passives, or progressives are incapable of absorbing the right-most affix in M.

Example 171 is a rendering of 170 in which the V is predicated on the O and the D is subjoined to the O. Thus it is analogous to our earlier Sentences 127 and 134 and is of the type indicated in 131.

Suppose next that the D of 170 does get 'promoted'. The result of introducing the D in this way as an immediate constituent of the P is 172.

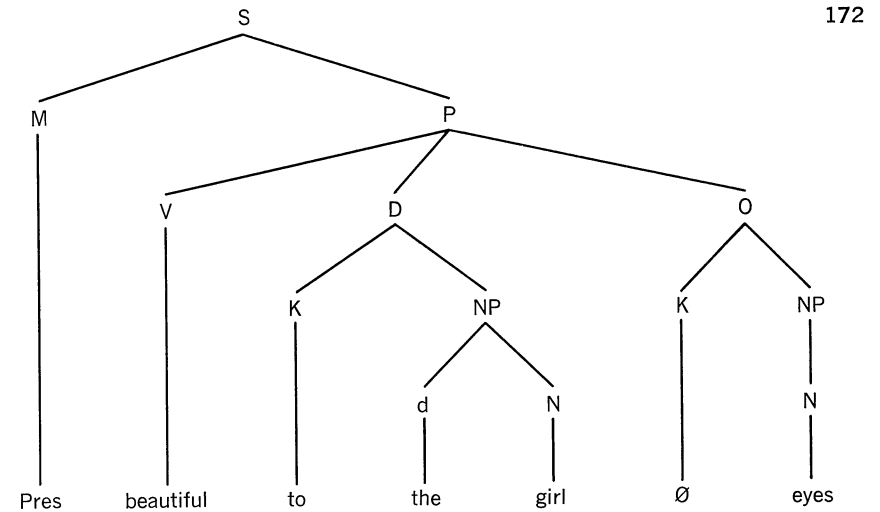

Some languages allow the O of Configuration 172 to become the subject and the D element to remain in the expected surface form for D, as in Sentence 132. Others allow the D element to undergo secondary topicalization when the O is subject, resulting, for example, in one case of the 'double subject' construction in Japanese (recall 142). The general expression type for sentences resulting from 172 when O becomes subject is suggested by the formula in 135 above.

Many languages allow the D to become subject. When this happens and there are no other changes, the O appears in some oblique case form. This is so because, since *beautiful* is not a true verb, the body-part word cannot be converted into an 'object'. The initial structure is seen in 173; it is one which is not typical of English, though it is perhaps seen in such expressions as those given in 174 and it may represent a stage in the derivation of a phrase of the type given in 175.

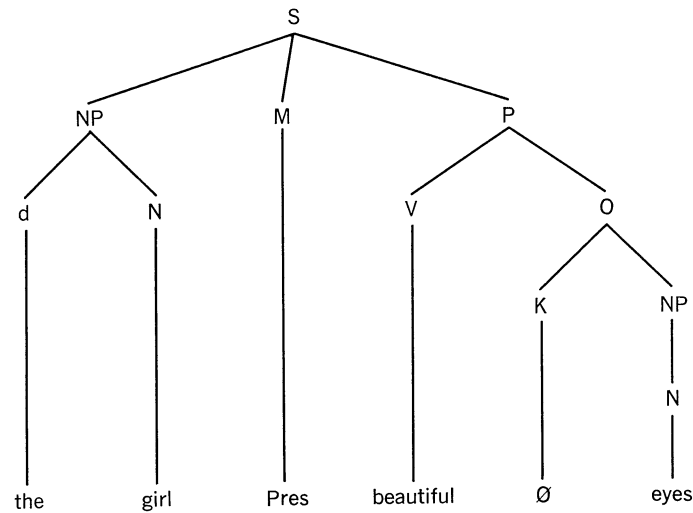

174. tall of stature, blue in the face
 175. broad-chested, fat-legged

It appears to be the structural form underlying 136, whose expression type is given in 137. The construction is apparently quite rare in French; Frei speaks of it as a 'short-circuited' version of the sentences with *have*.

Another possibility, when D is subject, is to attach the adjective to the NP indicating the body part. I propose, in an unhappily quite ad hoc fashion, that this be done without removing the constituent label V. I believe there are some arguments for retaining at least an abstract V under P at all times. This constraint may turn out to be better motivated than it seems, for this structure appears to reflect what was needed in those languages which adopted a verb like *have*.

The structure I have in mind is that shown in 176.

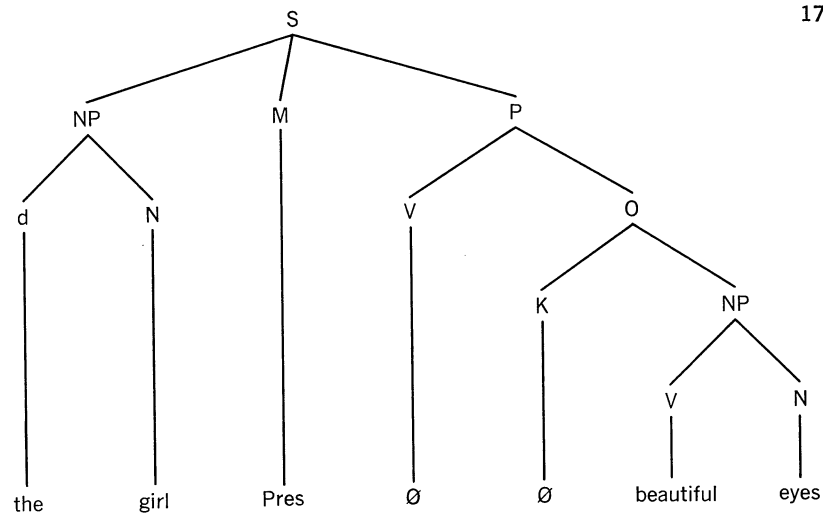

With the V under P vacant, a *be* must be added to the M in languages which allow structures of this type to become sentences directly. Notice that in this construction the modified body-part NP as a whole is 'in' some case form. The formula for this expression type has not yet been given; it would be something like 177.

177. $P\ be\ [A \rightarrow B]^{oblique}$

Conceivably this is the structure underlying such predicates as those shown in 178; the difference between predicates of the type in 137 and those of the type in 177 is seen in the Latin paraphrases of 179 and 180 respectively.

178. of tall stature; *di bello aspetto*
 179. *aequus animo*
 180. *aequo animo*

The last possibility, then, is to insert into the vacated V position the function word *have*, a verb which takes the modified body-part noun as its 'object'. In English, we have seen, this involves deleting the preposition. The result of modifying 176 in this way is 181.

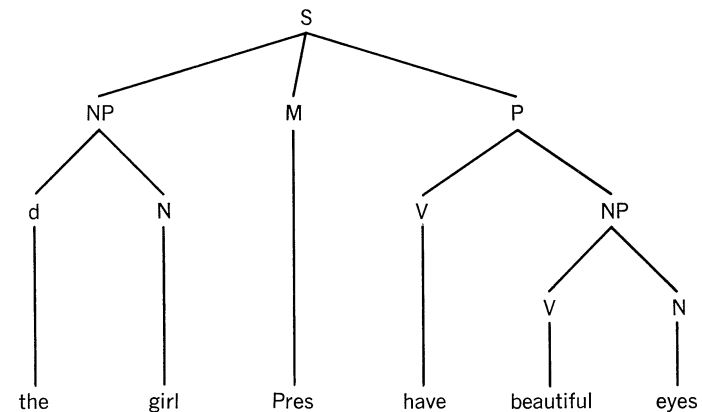

In short, it appears that the considerable surface variety found in sentences involving attribution of some property to an inalienable noun is to be accounted for by positing for universal grammar, in the spirit of Bach (1965), a set of recurrent transformations which each language uses somewhat in its own way. For sentences of the general structural type 182

182. $P[V^O[D + N]]$

where V is an adjective and N is a body-part noun, the options are *a* to *d* below:

- (a) promote D
- (b) choose D as subject
- (c) copy adjective into body-part NP
- (d) insert *have* into the vacated V

When *a* is not applied, the D becomes a genitive modifier of the body-part N and the whole O becomes the subject. When *b* is not applied, the O becomes the subject. When *c* is not applied, the 'short-circuited' sentences of Frei are the result. Rule *d* is available only to languages which have 'invented' *have*.

5.4 Further Remarks on Inalienable Possession

If the feature of inalienable possession is to be treated as a universal property of language, then either vocabulary items which are translations of each other will be categorized alike with respect to alienability, or the ways in which languages separately classify the 'same' things may possibly reflect differences in the psychic make-up of the speakers of different languages. Many scholars have seen in the data on inalienabilia an opportunity for the science of language to shed light on primitive mentality and on the possible range of man's concept of 'self'. Since the differences appear more and more to be differences on the level of surface structure, it may be advisable to wait some time before reaching any conclusions on these matters.⁶⁴

Adnominal D will certainly be needed for more than body-part nouns and names of relatives. Directional indicators like *right* and *left* are probably nouns of this type too. The reason that these words appear typically without any personal reference in English and many other languages is that they frequently refer to position or direction with respect to the speaker or addressee of the utterance, and there are simply many situations in which an adnominal D does not need to be expressed if it identifies speaker or hearer.

There are, too, many relational nouns which do not have a spe-

⁶⁴ For representative statements on the sociological relevance of the study of inalienable possession, see Lévy-Bruhl (1916, p. 103), Bally (1926, p. 68 *et passim*), Frei (1939, p. 192), and van Ginneken (1939, p. 90). For a catalogue of noun classifications based on grammatical differences associated with inalienable possession, see Rosén (1959, p. 268 f.).

cifically personal reference. We might wish to say that certain 'locational' nouns take an adnominal L. These nouns sometimes name parts of the associated objects, as in 183, and they sometimes identify a location or direction stated with reference to the associated object but not considered as a part of it, as seen in 184. 'Nouns' of the second type appear superficially as prepositions in English.

- 183. corner of the table, edge of the cliff, top of the box
- 184. behind the house, ahead of the car, next to the tower

6. Problems and Suggestions

There is a considerable residue of unsolved problems in the grammatical description of language phenomena, and it is disappointing though not surprising to realize how many of them remain unsolved under the formulation of grammar I have been suggesting. Those which come most quickly to mind are coordinate conjunction, nominal predicates, and 'cognate objects'.

6.1 Coordinate Conjunction

There may be a relationship between the ways in which languages deal with 'comitative' constructions and the phenomenon of coordinate conjunction of NP's. Put in case terms, there may be a relationship between conjunction of NP's and what one might wish to refer to as a comitative case. Jespersen noticed the parallels between *with* (a preposition which has a comitative function) and the conjunctive *and*, as in such pairs of sentences as 185 and 186 (1924, p. 90).

- 185. He and his wife are coming.
- 186. He is coming with his wife.

Japanese has separate devices for indicating sentence conjunction and NP conjunction, and the postposition used for NP conjunction is identical with the comitative postposition. In a conjunction of NP's, all but the last have the postposition *to*. The last one has the postposition appropriate for the case role of the whole NP. Compare 187 and 188.

- 187. *Tanaka-san to Hashimoto-san ga kimashita.*
'Mr. Tanaka and Mr. Hashimoto came.'
- 188. *Hashimoto-san ga Tanaka-san to hanashimashita.*
'Mr. Hashimoto spoke with Mr. Tanaka.'

Redden points out that in Walapai a sentence has only one noun in the 'nominative' case. Noun conjunctions are effected by having the 'ablative' suffix—the suffix with comitative function—on all but one of the nouns in a conjunction. Thus, in 189, /-č/ is nominative, /-m/ ablative.

189. /hàtθáuač hmápm/
'the dog and the boy' (lit. 'the dog with the boy')

It may be that the rule in 190 is needed as an expansion rule for NP.

190. NP → NP + C

Using *X* as a cover term for the various case categories, 190 will produce such structures as 191.

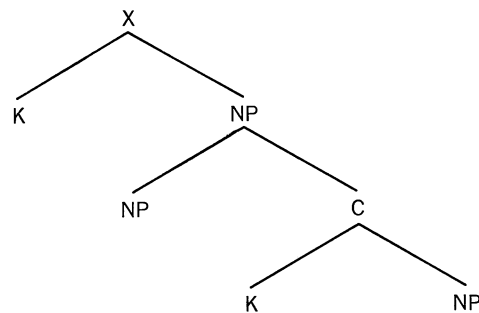

The case category C has a very special status, since the selectional constraints on nouns under C are those of the superordinate NP. What is needed, in other words, is a rule which imposes on any N under C the same redundant features that are associated with the dominating non-C case.

A subjoined C under some circumstances must remain in the large NP. In languages which lack a generalized conjunctive, the case marker is simply that appropriate to C (the postposition *to* in Japanese, the suffix *-m* in Walapai); in languages which have a generalized conjunctive, this word replaces the case marker, in the way that *and* replaces *with* under certain conditions.

The structure underlying 185 and 186, then, might be something like 192; we ignore the source of *his*.

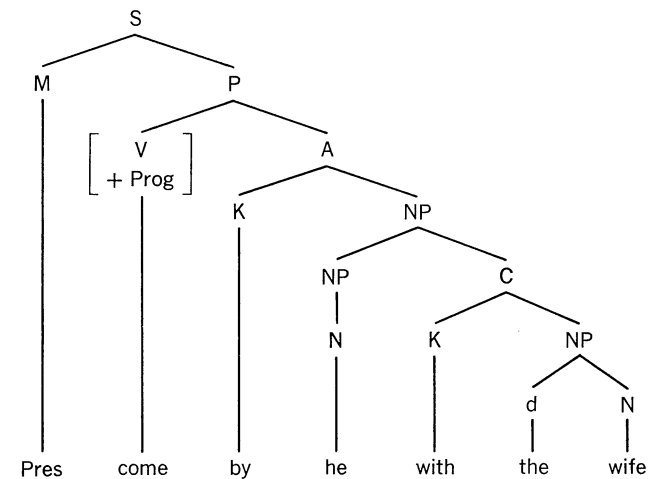

If the C remains inside the NP, the entire A becomes the subject, yielding Sentence 185; if the C is promoted, however, as in the structure shown in 193, it is left behind when the A becomes the subject, resulting in Sentence 186.

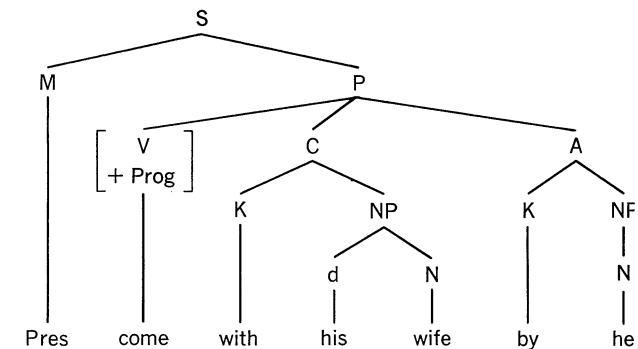

It is quite unlikely that the numerous problems associated with NP conjunction can be appreciably simplified through this approach, but that there is some connection between conjunction and comitative uses of NP's cannot be doubted. Lakoff and Peters (1966) have recently presented very persuasive arguments that the 'direction' of the relationship is the opposite of what I have suggested; that, in other words, comitative phrases are derived from NP conjunction rather than the other way around.

6.2 Nominal Predicates

Nothing that has been said so far suggests a way of providing for sentences of the *N be N* type. It is clear that they represent a distinct sentence type from those involving any of the case relations discussed above, though more than one case relationship may be involved in these sentences. (The terms *essive* and *translative* come to mind.)

Some nouns that appear in predicate position are restricted in their occurrence elsewhere. It might be possible to treat these nouns as, on one level, *V*'s which are restricted to the form [____ A]. Examples are words like *idiot*, *bastard*, and *fool*. The environment contains A because the subject is always animate and because the constructions exhibit selectional and transformational properties associated with *V*'s having A's in their environment. Notice 194 and 195.

194. Don't be a fool.
195. He's being a bastard again.

This interpretation appears to account for the fact that we have sentences like 196, but not—with *idiot* used in this same 'evaluative' sense—197.

196. John is an idiot.
197. An idiot hit the first homerun.

Further evidence that the word is properly treated as a *V* is found in the fact that these nouns may accept types of modification usually associated with adjectives, as in 198.

198. John is quite an idiot.

The serious problems are (a) with the use of words like *idiot*, *fool*, and so forth, in other contexts, as in 199, and (b) with the use of non-evaluative N's in predicate sentences, as in 200.

199. That rat swiped my lunch.
200. That boy is my nephew.

A new case category or two could be invented for the occasion, of course, but such matters as the requirement that subject and predicate NP's agree in number remain as serious as they ever were. Perhaps some solution is forthcoming along the lines of Bach's proposals elsewhere in this volume.

6.3 Cognate Objects

A difficulty of another sort is presented by the so-called 'cognate-object' constructions. These are constructions in which, at the very least, there is a high selectivity between a specific *V* and an 'object' N, and in which the *V + N* combination in one language might well be matched by a *V* alone in another.

Slightly modifying a recent analysis by Sandra Babcock (1966),⁶⁵ I would propose that there are contexts in which the case category F (factitive) may be left lexically empty, and that certain words classified as *V*'s may be inserted specifically into frames containing dummy F's. These words may have associated with them special N representatives (for example, *bath*) and special pro-*V*'s (for example, *take*). The rules that apply to dummy-F sentences are the following:

- (a) Copy the N-representative of the *V* under the F.
(b) Replace the *V* by the designated pro-*V*.

The rules may have separate conditions of optionality for different *V*'s. The cognate-object *V dream* may appear as a *V* in its own right, or it may appear in dummy-F sentences. As a cognate-object verb, it has *dream* as its N-representative and *have* as its pro-*V*; it is further specified as selecting either the preposition *about* or *of* for the O constituent and as not requiring Rule b.

When the N-representative associated with *dream* is copied into the F constituent, the result is Sentence 201; when the associated verb *have* replaces the *V*, the result is 202.

201. John dreamed a dream about Mary.
202. John had a dream about Mary.

With these devices, we may in fact consider extending the interpretation of cognate-object constructions in the following way. Some words may be treated as cognate-object *V*'s even though the rule for replacing the pro-*V* is obligatory. The *V nightmare*, for example, might have *nightmare* listed as its N-representative and *have* as its pro-*V*. Thus, on applying Rule a, the structure in 203 becomes the intermediate structure in 204; on applying Rule b, 204 is converted to 205. Analogous uses of this device could possibly account for the connection between *suggest* and *make a suggestion*, *shove someone* and *give someone a shove*, and so

⁶⁵ Compare too the interpretation in terms of 'quasi transformations' found in Harris (1957, Section 30).

on, but many serious problems remain. In particular it is not obvious how sentences like 206 and 207 can be dealt with in accordance with these proposals.

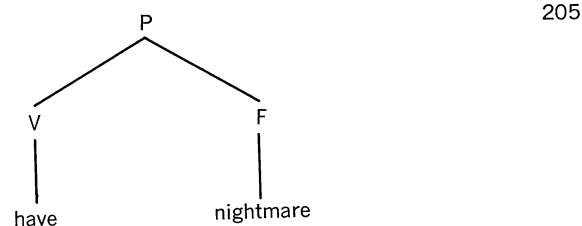
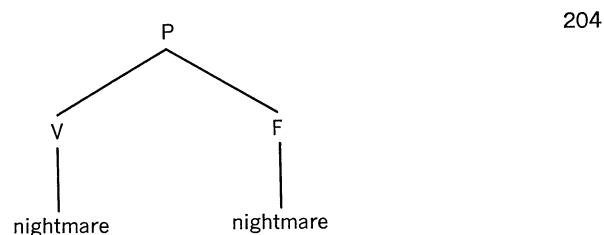
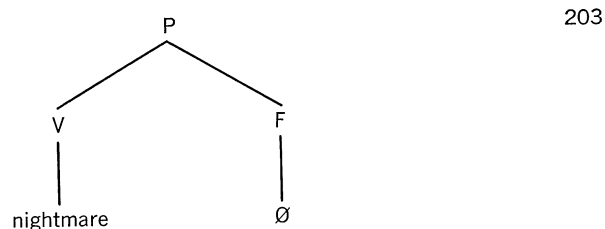

206. She made several ridiculous suggestions.

207. I had a terrible nightmare last night.

6.4 Other Problems

There are many issues for which I cannot even pretend to see solutions. The apparent connection between surface cases and 'partitive' functions; the restriction of 'definiteness' in some languages to NP's in particular surface-case relations (typically, the 'direct object'); the extreme variety of surface realizations of the same meaning (from the same deep structure?) that Jespersen illustrates in connection with what he calls 'rank shifting' (1924, p. 91), to name just a few.

The difficulties mentioned so far are empirical in nature, but many formal problems exist as well. One of these is whether the permitted arrays of cases under P need to be generated via phrase-structure rules, since one of the most important functions of the PS rules has been that

of defining grammatical relations—that is, that of defining phenomena which are here partly treated categorially rather than configurationally. Related to this problem are the apparent dependency relations that exist among cases. It appears, for example, that the occurrence of B (benefactive) phrases in a sentence has more to do with whether the sentence contains an A than with independent specific properties of V's. One is almost willing to allow these facts to be expressed by a generative process which chooses a verb, then the cases required by that verb, then the other cases that are compatible with the cases originally chosen. The issue is not whether the permitted sequences can or cannot be generated by PS rules—there is no doubt that they can—but whether the kinds of co-occurrence or dependency relationships that seem to obtain might not be more efficiently stated in some other way. (Modifications of transformational grammar of the type introduced in Chomsky (1965) made it no longer necessary to use PS rules for subclassification of lexical categories or for the choice of lexical items. If the provision of syntactic relations of certain kinds must also be handled by some device other than PS rules, there is a chance that rules of this type may be abandoned altogether.)

Whether the cases should be represented as categories dominating NP's or in some other way is an issue which seems to me to be fairly wide open. One advantage of the categorial treatment is that NP's made subject and object may be said to have lost their 'original' case relation to the sentence (by the rule which 'erases' the case category whenever the case marker K has been deleted—that is, a 'node-razing' rule) with the result that their form can only be determined by referring to their 'pure relational' status. Thus it would appear that the surface distinction between labeled and configurationally defined relations on NP's may correspond to the traditional distinction between the 'concrete' and the 'grammatical' cases. (How the genitive figures in this distinction is not clear under either interpretation.)

Several people have pointed out to me the apparent convertibility of underlying representations in case grammar into objects which resemble dependency diagrams and tagmemic formulas. If the K elements are interpreted as constituents of NP's, then the case categories *unarily* dominate NP's. This makes them equivalent to *labels on the branches that link P with the various NP's that are directly related to it*. If the only function of the P is to provide a constituent in terms of which the NP's can be related to the V, one may just as well represent these relationships more directly by replacing the node P by the V. The result is no longer a diagram of constituent structure, since lexical elements are inserted into 'dominating' nodes; but it may turn out to be just as possible to represent the needed constituent organization of sentences from a 'stem-

matic' diagram of the type used by Tesnière or Hays, as from a phrase-structure tree diagram.

There is an easy conversion from underlying representations of case grammar to 'tagmemic' formulas, too, as long as the case categories *unarily* dominate NP's. Or, for that matter, a case-grammar diagram could simply be read off as a tagmemic formula, as long as certain symbols were designated as function indicators. One can as easily say 'NP filling an A slot' as anything else. The crucial difference between the modification of transformational grammar that I have been suggesting and the typical tagmemic study is in the insistence here on discovering the 'deepest' level of the 'deep structure'.

7. Closing Words

One criticism of case grammar that has been brought to my attention is that it is too strongly motivated by semantic considerations. Many of the analyses have (hopefully) the result that certain semantic distinctions and interlanguage commonalities are revealed in fairly direct ways in the deep structures of case grammar, but, it has been argued, syntactic analyses should be based on syntactic data alone and on one language at a time.

The question arises whether there is a 'level' of syntactic description that is discoverable one language at a time on the basis of purely syntactic criteria. If it is possible to discover a semantically justified universal syntactic theory along the lines I have been suggesting, if it is possible by rules (beginning, perhaps, with those which assign sequential order to the underlying order-free representations) to make these 'semantic deep structures' into the surface forms of sentences, then it is likely that the syntactic deep structure of the type that has been made familiar from the work of Chomsky and his students is going to go the way of the phoneme. It is an artificial intermediate level between the empirically discoverable 'semantic deep structure' and the observationally accessible surface structure, a level the properties of which have more to do with the methodological commitments of grammarians than with the nature of human languages.

Edited by

Emmon Bach/Robert T. Harms *The University of Texas at Austin*

Contributing Authors

Charles J. Fillmore *The Ohio State University*

Paul Kiparsky *Massachusetts Institute of Technology*

James D. McCawley *The University of Chicago*

UNIVERSALS
IN LINGUISTIC
THEORY

Holt, Rinehart and Winston, Inc.

New York Chicago San Francisco

Atlanta Dallas Montreal

Toronto London